

Lunar Net—a proposal in response to an ESA M3 call in 2010 for a medium sized mission

Alan Smith · I. A. Crawford · Robert Anthony Gowen · R. Ambrosi · M. Anand · B. Banerdt · N. Bannister · N. Bowles · C. Braithwaite · P. Brown · J. Chela-Flores · T. Cholinser · P. Church · A. J. Coates · T. Colaprete · G. Collins · G. Collinson · T. Cook · R. Elphic · G. Fraser · Y. Gao · E. Gibson · T. Glotch · M. Grande · A. Griffiths · J. Grygorczuk · M. Gudipati · A. Hagermann · J. Heldmann · L. L. Hood · A. P. Jones · K. H. Joy · O. B. Khavroshkin · G. Klingelhofer · M. Knapmeyer · G. Kramer · D. Lawrence · W. Marczewski · S. McKenna-Lawlor · K. Miljkovic · S. Narendranath · E. Palomba · A. Phipps · W. T. Pike · D. Pullan · J. Rask · D. T. Richard · K. Seweryn · S. Sheridan · M. Sims · M. Sweeting · T. Swindle · D. Talboys · L. Taylor · N. Teanby · V. Tong · S. Ulamec · R. Wawrzaszek · M. Wieczorek · L. Wilson · I Wright

Received: 31 March 2011 / Accepted: 4 August 2011
© Springer Science+Business Media B.V. 2011

A. Smith · R. A. Gowen (✉) · A. J. Coates · A. Griffiths
Mullard Space Science Laboratory, University College London, Holmbury St Mary,
Dorking, Surrey, RH5 6NT, UK
e-mail: rag@mssl.ucl.ac.uk

A. Smith
e-mail: as@mssl.ucl.ac.uk

I. A. Crawford · V. Tong
Department of Earth and Planetary Sciences, Birkbeck College, University of London,
London, UK

P. Brown · G. Collins · W. T. Pike · K. Miljkovic · W. T. Pike
Imperial College London, London, UK

A. P. Jones
Department of Earth Sciences, University College London, Gower Street, London,
WC1E 6BT, London, UK

Y. Gao
Surrey Space Centre, University of Surrey, Guildford, UK

P. Church
QinetiQ Ltd., Fort Halsted, Sevenoaks, UK

M. Anand · A. Hagermann · S. Sheridan · I. Wright
CEPSAR, Open University, Milton Keynes, UK

R. Ambrosi · N. Bannister · G. Fraser · D. Pullan · M. Sims · D. Talboys
University of Leicester, Leicester, UK

Abstract Emplacement of four or more kinetic penetrators geographically distributed over the lunar surface can enable a broad range of scientific exploration objectives of high priority and provide significant synergy with planned orbital missions. Whilst past landed missions achieved a great deal, they have not included a far-side lander, or investigation of the lunar interior apart from a very small area on the near side. Though the LCROSS mission detected water from a permanently shadowed polar crater, there remains in-situ confirmation, knowledge of concentration levels, and detailed identification of potential organic chemistry of astrobiology interest. The planned investigations will also address issues relating to the origin and evolution of the Earth–Moon system and other Solar System planetary bodies. Manned missions would be enhanced with use of water as a potential in-situ resource; knowledge of potential risks from damaging surface Moonquakes, and exploitation of lunar regolith for radiation shielding. LunarNet is an evolution of the 2007 LunarEX proposal to ESA (European Space Agency) which draws on recent significant advances in mission definition and feasibility. In particular, the successful Pendine full-scale impact trials have proved impact survivability for many of the key technology items, and a penetrator system study has greatly improved

C. Braithwaite
Cavendish Laboratory, Cambridge, UK

A. Phipps · M. Sweeting
SSTL, Tycho House, 20 Stephenson Road, Guildford, UK

L. Wilson
Lancaster University, Lancaster, UK

N. Teanby
School of Earth Sciences, University of Bristol, Wills Memorial Building, Queen's Road
Bristol, BS8 1RJ, UK

N. Bowles
Oxford University, Oxford, UK

T. Cook · M. Grande
Institute of Mathematical and Physical Sciences, University of Wales Aberystwyth,
Aberystwyth, UK

S. McKenna-Lawlor
Space Technology Ireland, National University of Ireland, Maynooth,
Co. Kildare, Ireland

J. Grygorczuk · W. Marczewski · K. Seweryn · R. Wawrzaszek
Space Research Centre, Polish Academy of Sciences, Warsaw, Poland

E. Palomba
IFSI-INAF, Rome, Italy

J. Chela-Flores
The Abdus Salam International Centre for Theoretical Physics, Trieste, Italy

the definition of descent systems, detailed penetrator designs, and required resources. LunarNet is hereby proposed as an exciting stand-alone mission, though is also well suited in whole or in-part to contribute to the jigsaw of upcoming lunar missions, including that of a significant element to the ILN (International Lunar Network).

Keywords Moon · Lunar · Penetrators · Space · Technology · MEMS

1 Overview

LunarNet is a proposal for a penetrator mission to the Moon, submitted to ESA in December 2010 in response to ESA's call for medium class missions suitable for launch in 2022 [12]. This paper presents that proposal in full, together with some small changes to incorporate additional knowledge gained since submission.

G. Klingelhofer
Institute for Inorganic and Analytic Chemistry, Johannes Gutenberg-University,
Mainz, Germany

M. Wieczorek
Institut de Physique du Globe de Paris, Univ Paris Diderot, Paris, France

M. Knapmeyer
DLR, Institute of Planetary Research, Berlin, Germany

S. Ulamec
DLR-MUSC, Cologne, Germany

O. B. Khavroshkin
Institute of Physics of the Earth, Russian Academy of Sciences, Moscow, Russia

S. Narendranath
ISRO, Bangalore, India

T. Cholinsier
Hong Kong, China

G. Collinson
NASA Goddard Spaceflight Center, Greenbelt, MD 20771, USA

T. Colaprete · J. Rask
NASA Ames, Moffett Field, CA 94035, USA

D. Lawrence
Johns Hopkins APL, 11100 Johns Hopkins Road, Laurel, MD 20723, USA

T. Glotch
Stony Brook University, Stony Brook, NY 11794, USA

While the surface missions to the Moon of the 1970s achieved a great deal scientifically, major questions in lunar science were left unresolved. The recent plethora of lunar missions (flown and proposed) reflects a major resurgence of interest in the Moon, not only in its own right, but also as a record of the early solar system including the formation and evolution of the early Earth. Results from recent orbiter missions have shown evidence of ice within shadowed craters at the lunar poles, and Chandrayaan-1 has detected OH-HOH over major portions of the Moon.

We propose a highly cost effective M-class lunar mission that will place four or more scientifically instrumented penetrators into the shallow lunar surface.

LunarNet will address key issues related to the origin and evolution of planetary bodies as well as the astrobiologically important possibilities associated with polar ice. LunarNet will provide important information about:

- The size and physical state of the lunar core
- The deep structure of the lunar mantle
- The thickness of the far-side lunar crust
- The nature of natural Moonquakes, in particular the origin of shallow Moonquakes
- The composition and thermal evolution of the Moon's interior
- The existence, nature and origin of polar ice—exciting scientifically and key to future manned exploration of the Moon and beyond

The penetrators will be globally dispersed (unlike the Apollo and Luna missions) with landing sites on the nearside Procellarum KREEP Terrane, poles and far-side, and will operate 2–5 m beneath the lunar surface for 1 year.

L. L. Hood · T. Swindle
Lunar and Planetary Laboratory, University of Arizona, Tucson, AZ, USA

D. T. Richard
San Jose State University/NASA Ames Research Center MS 245–3, Moffett Field,
CA 94035 USA

R. Elphic · J. Heldmann
NASA Ames Research Center, Moffett Field, CA 94035-1000, USA

L. Taylor
University of Tennessee, Knoxville, 37996, USA

E. Gibson
NASA Johnson Space Center, 2101 NASA Road 1, Houston, TX 77058, USA

B. Banerdt · M. Gudipati
Jet Propulsion Laboratory, 4800 Oak Grove Drive, Pasadena, CA 91109, USA

K. H. Joy · G. Kramer
Center for Lunar Science and Exploration, Lunar and Planetary Institute,
3600 Bay Area Blvd., Houston, TX 77058, USA

Each penetrator will include a suite of scientific instruments including micro-seismometers, a geochemistry package, a water/volatiles detector, a heat flow experiment, and an impact accelerometer.

For an instrument to survive an impact at 300 m s^{-1} is entirely feasible and a vast amount of resources have been devoted to developing such capability within a defence context. ‘Penetrators’ are common-place within that sector and instrumentation is available off-the-shelf which will survive impacts of $>50,000 \text{ gee}^1$ (LunarNet expects $<20,000 \text{ gee}$). This expertise is by no means purely empirical in nature; and a very sophisticated predictive modelling capability also exists. The UK penetrator consortium has already drawn on this expertise to rapidly achieve the successful full-scale ground demonstration of impact survivability into a lunar regolith simulant. Also, Mars 96 [60], DS-2 [58], and Lunar-A [38] penetrator development programmes have already overcome many key problems and demonstrated payload survivability in ground tests.

The penetrator delivery to the lunar surface will take place in two stages:

- The penetrators will be transferred to lunar orbit as the payload of what will become a polar orbit communications relay satellite
- Release, de-orbit and descent. Each penetrator will have an attached de-orbit motor and attitude control system (both of which are ejected before impact)

The mission is compatible with a single Soyuz-Fregat launch for a nominal four penetrator payload with a 30% mass contingency.

LunarNet will fill an important gap within the proposed international lunar mission portfolio (including the ILN) and facilitate future scientific exploration of the Moon.

2 Introduction

2.1 The Moon

The principal scientific importance of the Moon is as a recorder of geological processes active in the early history of terrestrial planets (e.g. planetary differentiation, magma ocean formation and evolution), and of the near-Earth cosmic environment (e.g. bombardment history, solar wind flux and composition) throughout Solar System history (e.g. [9, 30, 45, 59]). Some of these objectives are astrobiological in nature, in that they will enhance our understanding of the cosmic conditions under which life first arose on Earth [10].

Although recent space missions (e.g. *Clementine*, *Lunar Prospector*, *Kaguya*, *Chandrayaan-1*, and the *Lunar Reconnaissance Orbiter*) have greatly

¹‘gee’ is used here to represent the unit of acceleration equal to gravity at the surface of Earth.

added to our knowledge of the topography, geochemical and mineralogical makeup of the lunar surface, our knowledge of the deep interior still largely relies on geophysical measurements made during the Apollo programme.

As can be seen from Fig. 1, the Apollo landing sites are all located at low to mid-latitudes close to the centre of the lunar nearside, and were thus unable to provide global coverage. Moreover, the recent orbital missions have uncovered evidence for hydrated minerals, polar ice deposits, and ‘exotic’ lunar lithologies which have not yet been sampled in situ by any lunar mission.

In order to follow-up on these earlier results, and thus advance our knowledge of the origin, internal structure and evolution of the Moon, the LunarNet mission will fly four penetrators to the Moon for the purpose of conducting a range of in situ geophysical and geochemical measurements at widely separated localities.

2.2 Penetrators

Penetrators are small, instrumented probes which impact planetary bodies at high speed and bury themselves in the planetary surface. For the Moon we propose deployment of four 13 kg penetrators that are designed to survive impact at high speed ($\sim 300 \text{ m s}^{-1}$) and penetrate $\sim 2\text{--}5 \text{ m}$. The impact process generates decelerations of $>10,000 \text{ gee}$, which together with the low available mass, restricts the type and capability of payload that can be accommodated. However, a surprisingly large range of instruments have already been

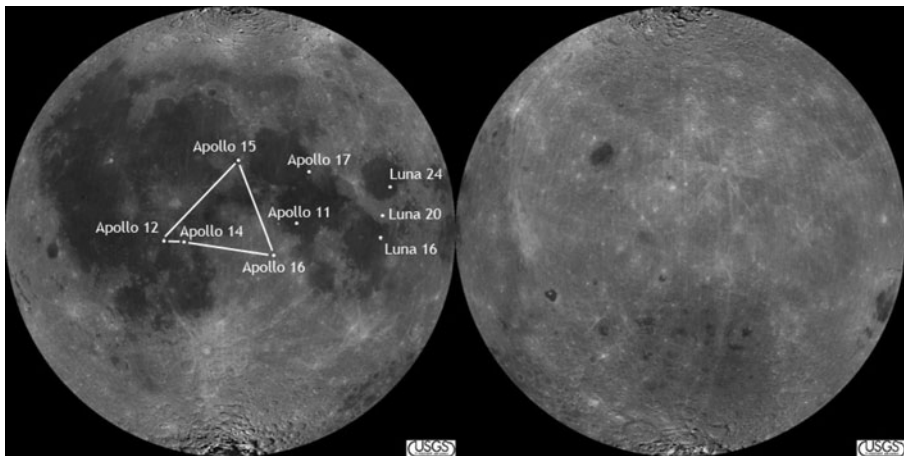

Fig. 1 Locations of the Apollo and Luna landing sites on the nearside of the Moon (*left*); the farside is at *right*. These are the only locations from which lunar samples have been returned to Earth for analysis. The Apollo seismic network occupied an approximate equilateral triangle, roughly 1200 km on a side, as indicated. The two Apollo heat-flow measurements were made at the Apollo 15 and 17 sites. No long-term geophysical measurements were made at the Apollo 11 site. Note the geographically restricted nature of these measurements (Image courtesy Katherine Joy/USGS)

constructed and qualified for penetrator use, and an ever widening range of scientific instruments have a robust nature which lend themselves to the necessary ruggedisation.

Survival at these impact speeds has been demonstrated by ground tests conducted for NASA DS2, Mars 96 and Japanese Lunar-A probes, and extensive military experience of impacts into materials mostly consisting of sand, concrete, steel and ice. In 2008 highly successful full-scale trials of penetrator technology were undertaken in Pendine (see Fig. 2) [56].

Penetrators were earlier proposed for the UK (United Kingdom) led Moon-LITE mission with significant NASA and international support, and later rebadged as LunarEX [55] for an earlier ESA call (which was unsuccessful at that time).

General interest in penetrators has also grown, as reflected in the recent completion of an ESA study into a penetrator mission to Europa as part of Laplace/EJSM, and potential application to the exploration of the interior structure and astrobiological potential of Mars. The report of this ESA study also informs the present LunarNet proposal [2].

2.3 Current and future space missions

The present LunarNet proposal builds upon a growing interest in missions to the Moon. The scientific objectives of LunarNet are complementary to the goals of ESA's Lunar Lander project (http://www.esa.int/esaCP/SEMUV2KOXDG_index_0.html, accessed 27 March 2011), which is managed by D-HSF (Department of Human Space Flight) and aims to deploy a soft lander at the lunar south pole to characterise this environment for future human exploration. As the Lunar Lander mission would only conduct measurements in one particular locality, the wider geographical spread of measurements obtained from a penetrator-based mission such as LunarNet would lead to a much broader understanding of the wider lunar environment. This enhanced investigation is crucial for both improved scientific understanding of the Moon and its environment, and for planning future exploration activities.

Fig. 2 Penetrator intact after impact at Pendine



LunarNet could also provide technical assistance to future astronauts by determining: the effectiveness of lunar regolith for human radiation shielding; the frequency and location of possibly structurally damaging surface Moonquakes; and acquiring further information concerning the concentration and extent of water in the polar regions, in particular in the permanently shaded craters. Such water will be important for astronauts as a source for drinking, and for the manufacturing of air and propellant.

LunarNet should also be seen in the context of a number of international lunar initiatives, including the Global Exploration Strategy [17]. The UK is a signatory to the International Lunar Network which aims to coordinate lunar un-manned landed science packages. LunarNet can be seen as a pre-cursor or early element of a more extensive global network. Moreover, LunarNet builds upon other proposed penetrator missions including DS-2 (Deep Space-2) [58], Polar Night [41] and, in particular, Lunar-A [39]—a similar, albeit discontinued Japanese mission.

3 Scientific objectives and requirements

The principal scientific objectives of the LunarNet penetrator mission are as follows:

- Constraining the origin, differentiation, internal structure and early geological evolution of the Moon.
- Develop a better understanding of the origin and history of the volatile flux in the Earth–Moon system.
- Collect ‘ground truth’ geochemical data to calibrate orbiting remote-sensing instruments.
- Collect in situ surface data that will help in the planning of future lunar exploration.

The top-level science objectives for LunarNet fall into four research domains according to the type of measurement required: seismology, heat-flow, geochemical analysis, and the characterisation of polar volatiles. These objectives address three of the top four key ‘lunar science concepts’ identified by the US National Research Council’s Report on *The Scientific Context for Exploration of the Moon* [45], and this comparison is made directly in Table 1.

3.1 Lunar seismology

Determining the structure of the lunar interior was the second highest scientific objective for lunar science identified by NRC ([45]; see their Table 1). Seismology is the most powerful geophysical tool available for determining the interior structure of a planetary body. However, to-date the only object, other than the Earth, where it has been successfully applied is the Moon, where the Apollo missions deployed a network of four highly sensitive seismometers close to the centre of the nearside. The Apollo seismometers remained active for up to

Table 1 Comparison of proposed LunarNet measurements with the four highest priority ‘lunar science concepts’ identified by NRC [45]

Key lunar science concept [45]	Relevant LunarNet measurements
The bombardment history of the inner solar system is uniquely revealed on the Moon	N/A (requires in situ dating or, preferably, sample return from multiple localities)
The structure and composition of the lunar interior provide fundamental information on the evolution of a differentiated planetary body	Seismology and heat-flow measurements at widely-spaced localities
Key planetary processes are manifested in the diversity of lunar crustal rocks	Geochemistry measurements of regolith at previously unsampled sites
The lunar poles are special environments that may bear witness to the volatile flux over the latter part of solar system history	Polar volatile detection and characterisation measurements in shadowed polar craters

eight years, and provided important information on the Moon’s natural seismic activity, and on the structure of the lunar crust and upper mantle (see [21, 33] for reviews). However, the deep interior of the Moon was only very loosely constrained by the Apollo seismology, although heroic efforts continue to be made to extract the maximum possible information from this unique dataset (e.g. [31, 33, 66]).

The Apollo seismometers were deployed in a geographically limited triangular network (between Apollo 12/14, 15 and 16; Fig. 1) on the nearside. In consequence, the information obtained on crustal thickness and upper mantle structure strictly only refers to the central nearside and may not be globally representative. Moreover, seismic waves capable of probing the deep interior had to originate close to the centre of the far-side, and were therefore limited to rare, relatively strong, events. Indeed, the tentative seismic evidence for a lunar core arises from the analysis of just one far-side meteorite impact that was sufficiently strong to be detected by more than one nearside Apollo seismic station in eight years of operation. This is clearly an unsatisfactory state of affairs, and there is a pressing need for a much more widely-spaced network of lunar seismic stations, including stations at high latitudes and on the far-side. Penetrators delivered from orbit are ideally suited to achieve emplacement of a global seismometer network, which would address the scientific issues addressed in the following subsections.

3.1.1 Size and physical state of lunar core

Most of our knowledge on the size and physical state of the lunar core has been obtained from studies of the Moon’s moment of inertia, physical librations (as determined by laser reflector measurements), and electromagnetic induction studies (see [69] for a review). These studies favour a small ($R < 400$ km) partially liquid core, with suggested compositions ranging from iron-nickel, Fe-FeS alloy, or molten silicates. Until recently, the Apollo seismic data were unable to place any meaningful constraints on the core size and state, though Weber et al. [66] have re-analysed the Apollo data using array processing

methods and found suggestions of core reflected phases consistent with a fluid outer core of radius 330 km and a solid inner core of radius 240 km. However, these results are at the edge of detectability from the Apollo data and still require corroboration with modern, and geographically well-spaced, seismic instrumentation.

Information on the size, composition and physical state of a lunar core would have profound impacts on our understanding of the Moon's origin, mantle evolution, and magnetic history. The latter point, when combined with studies of remanent magnetisation of surface rocks, will have important implications for our understanding of the origin and evolution of planetary magnetic fields. For these reasons, constraining the nature of a lunar core is the top scientific priority of the proposed penetrator-deployed seismic network.

3.1.2 Deep structure of the lunar mantle

One of the main contributions lunar science can make to planetary science more generally is an enhanced understanding of the internal differentiation processes that occur immediately after the accretion of a terrestrial planet. Magma oceans are likely to have been a common phase in the early evolution of all rocky planets, and, in contrast to the more evolved mantles of the larger terrestrial planets, the structure of the lunar mantle may preserve a record of these early times. Seismology may help elucidate these processes in several ways.

Primarily, seismology may be able to determine the initial depth of the magma ocean, and thus the fraction of the Moon's volume that was initially molten. The Apollo data appear to indicate a seismic discontinuity at a depth of about 550 km, which is sometimes interpreted as the base of a magma ocean (see review by [69]). However, because of the placement of the Apollo seismometers, it is not currently known whether this discontinuity is global in extent or exists only under the nearside. A competing explanation is that it represents the depth to which late partial melting occurred which led to the formation of the nearside mare basalts. As noted by Wiczorek et al. [69], differentiating between these two possibilities is of key importance in understanding lunar mantle evolution.

In addition, we note that the radii recently inferred by Weber et al. [66] for the inner and outer lunar core, as well as the radius of a possible partial melt layer at the base of the mantle, are sensitive to variations in seismic wave speed in the mantle. Therefore, an improved model of the lunar mantle, such as LunarNET would also provide better constraints on the properties of the core. Moreover, measurements of seismic wave speed as a function of depth can help constrain the mineralogy of the mantle (e.g. [34]). This in turn may be used to constrain both the bulk composition of the Moon (and thus its origin), and the crystallisation history of the lunar mantle and its implications for magma ocean evolution. Again, new, and more widely spaced, seismic data are required if advances are to be made over what has been learned from the Apollo data.

3.1.3 Thickness of the far-side lunar crust

Re-interpretations of the Apollo seismic data have now constrained the thickness of the nearside anorthositic crust to about 30–40 km [31, 34, 69]. However, the thickness of the far-side crust has not been constrained seismically at all. Estimates based on gravity data are typically in the range 70–90 km [69]; although gravity data obtained from the Kaguya mission indicate that some far-side areas (e.g. the South Pole-Aitken Basin (SPA) and Mare Moscoviense) have substantially thinner crust (e.g. [1]). However, many of these interpretations are non-unique, and in particular depend on whether the lunar highland crust should be considered as a single anorthositic layer, or as two layers, with the lower layer having a more mafic (Fe-rich) composition. Far-side measurements are required in order to determine the average lunar crustal thickness which, because of its very aluminium-rich nature, has significant implications for understanding the bulk composition (and thus origin) of the Moon.

There is considerable interest in the thickness of the crust (if any) remaining under the giant South Pole-Aitken impact basin—the largest impact structure currently known in the Solar System. Together with the nearside Procellarum KREEP Terrain on the nearside (well studied by Apollo) and the far-side highlands, the floor of the SPA forms one of the three main lunar terrains identified by Jolliff et al. [29]. Part of the interest in the SPA lies in the possibility that it may feature exposed lower crustal or upper mantle materials. Seismometers located within the SPA will, for the first time, be able to make definitive measurements of the crustal thickness remaining under this important structure.

3.1.4 Studies of natural Moonquakes

The Apollo seismometers detected four types of natural Moonquake: (1) deep (700–1200 km), relatively weak, Moonquakes which occur in ‘nests’ and which appear to have a tidal origin [4, 13]; (2) shallow (5–200 km), relatively strong, Moonquakes of unknown origin; (3) thermal Moonquakes due to thermal stresses in the near surface; and (4) meteorite impacts (summarised by Vaniman et al. [65]).

Of these (1), (2) and (4) may be used as sources of seismic energy to probe the lunar interior. A better understanding of the causes and clustering of (1) will provide additional knowledge concerning the physical properties of the deep lunar interior.

Re-observation of the known deep-quake clusters (given they are still active), and observation of new clusters, which may also occur on the far side, could help improve our understanding of the tidal triggering mechanism, and its implications on the interior structure of the Moon.

However, it is the shallow Moonquakes (2) that are probably the most interesting scientifically. These were the strongest (up to magnitude 5) and rarest (only 28 recorded in 8 years), and currently their cause is unknown.

Suggestions, as to their origin, range from thermal stress release [3] to impacts of high-speed meteoroids [15]. Insofar as these result from unknown tectonic processes, our knowledge of present-day lunar geological activity will remain incomplete until their cause and locations can be identified (e.g. [42]). Owing to the spatially restricted locations of the Apollo seismic stations, the Apollo data lacks the resolution required to pinpoint the precise epicentres or depths of these events, for which a global distribution of seismometers will be required.

Understanding shallow events is also important in the context of future lunar exploration. For example, a magnitude 4–5 Moonquake is sufficiently strong that it would be prudent not to construct a lunar base at localities where they are likely to occur [44]. Some scenarios for future lunar exploration also envisage placing optical astronomical instruments on the lunar surface, and knowledge of lunar seismicity could be useful in deciding where to site such instruments. Thus, in addition to providing fundamental information about lunar geophysics, a better understanding of the origins and locations of shallow Moonquakes would make a significant contribution to future lunar exploration.

3.2 Lunar heat-flow

Measurements of surface heat-flow provide valuable constraints on the composition and thermal evolution of planetary interiors. To date, the only planetary body other than the Earth for which surface heat-flow has been measured in situ is the Moon, during the Apollo 15 and 17 missions [32]. However, both these measurements were relatively close together on the nearside (Fig. 1) and may thus not be representative of lunar heat-flow as a whole [25]. Moreover, both these Apollo measurements have been subject to numerous re-interpretations over the years, owing to uncertainties in determining the thermal conductivity of the regolith, the extent to which the temperature sensors were in contact with the regolith, and the uncertain effects of local topography (both measurements were very close to highland/mare boundaries).

One particularly important measurement would be to determine the heat-flow as a function of distance from the Procellarum KREEP Terrain (PKT) in the north-western part of the lunar nearside. Remote sensing measurements have determined that the heat-generating elements (U, Th, K) are concentrated at the surface in this area of the Moon (high Th concentrations have been measured by the Lunar Prospector spacecraft around and to the south of the Imbrium basin on the nearside), but a question remains over whether this is a surficial effect (owing to excavation of a global underlying layer of incompatible element-rich material by the Imbrium impact), or whether these elements are indeed concentrated in the mantle below the PKT. The latter scenario predicts a much higher heat-flow in the PKT than elsewhere, and this would have major implications for our understanding of the early differentiation and crystallization of the Moon (e.g. [68]). While the Apollo 15

and 17 data do appear to indicate a decrease in heat-flow away from the PKT (21 ± 3 and 16 ± 2 mW m⁻², respectively; [32]), the experimental uncertainties are such that it is far from clear that this trend is statistically significant. In addition, Hagermann and Tanaka [26] have drawn attention to fact that the Apollo results may simply reflect the different thicknesses of (U, Th, K-rich) Imbrium ejecta at the two Apollo sites, and not the underlying mantle heat-flow.

For all these reasons there is a pressing need to extend these measurements to new localities, ideally close to the centres of the three lunar terrain types [i.e. the PKT, the Feldspathic Highland Terrain (FHT), and the SPA] identified by Jolliff et al. [29]. Such measurements would greatly aid in constraining models of lunar thermal evolution. Finally, we note that in situ measurements of both the temperature and the thermal conductivity of the regolith would provide “ground-truth” for temperatures obtained by radiometer observations from orbit (e.g. [47]). Penetrator deployment of a global heat-flow network would provide an attractive means of achieving these objectives.

3.3 In situ geochemistry

Understanding the diversity of lunar crustal rock types was one of the highest scientific priorities identified by NRC ([45]; see Table 1), and this requires the detailed chemical and mineralogical analysis of rocks and soils. The only places on the Moon from which samples have been collected in situ are the six Apollo landing sites and the three Russian Luna sample return missions from near the Crisium basin on the eastern limb of the nearside (Fig. 1). No samples have been returned from the polar regions or the far-side, thus greatly limiting our knowledge of lunar geological processes. Although, statistically, many of the 140 or so known lunar meteorites must originate from these unsampled regions, the provenance, and thus geological context, of any given meteorite is unknown, which limits their value in interpreting lunar geology.

Although sample return missions to currently unsampled regions would be the preferred means of furthering our knowledge of lunar geological diversity, this may not be practical in the short term. An alternative would be to make in situ geochemical measurements, at least of the abundances of the major rock-forming elements (e.g. Mg, Al, Si, K, Ca, Fe and Ti). In principle, various instruments would be capable of making such measurements, including X-ray spectroscopy, gamma-ray spectroscopy, and/or laser-induced-breakdown spectroscopy (LIBS). Depending on their sensitivity, some of these instruments may also be able to measure minor and trace elements and isotopes, many of which provide key diagnostic information regarding the origin and ages of geological materials. Penetrator-deployed instruments of this kind therefore have the potential to determine the composition of lunar materials in regions remote from areas sampled to-date. In addition such measurements would provide additional ‘ground truth’ for the calibration of remote-sensing observations performed by orbiting spacecraft.

The diversity of lunar crustal materials has been highlighted most recently by the detection of spectral signatures of “evolved” (quartz-rich) lithologies by the Diviner instrument on LRO (Lunar Reconnaissance Orbiter) [20, 23]. These rock types are very rare in the Apollo sample collection (occurring only as small clasts in brecciated rocks), and the discovery of quite extensive outcrops by LRO has important implications for understanding the magmatic evolution of the Moon. It is therefore important to confirm the interpretation of the remote-sensing data as no ‘ground-truth’ has yet been obtained for any of these localities, and compositional identifications based on surface feature morphology (e.g. [71]) have considerable uncertainties. It is also important to obtain measurements of minor and trace elements which cannot be detected by orbital remote-sensing instruments, but which would help discriminate between different suggested formation mechanisms regarding these materials (e.g. [20]). Targeting suitably instrumented penetrators to these localities, as proposed here, would be an attractive (and certainly cost effective) means of obtaining these necessary measurements, especially as dedicated sample return missions to these sites are unlikely to be realised in the near-term.

3.4 Polar volatiles

As noted in the NRC Report on the Scientific Context for Exploration of the Moon ([45]; Table 1), the lunar poles potentially bear witness to the flux of volatiles present in the inner Solar System throughout much of Solar System history. The possibility of extensive volatile deposits at the lunar poles was highlighted in 1998 when the *Lunar Prospector* neutron spectrometer found evidence of enhanced concentrations of hydrogen at the lunar poles. This was widely interpreted as indicating the presence of water ice in the floors of permanently shadowed polar craters [14]. This interpretation now appears to have been confirmed by the LCROSS impact experiment, which found a water ice concentration of $5.6 \pm 2.9\%$ by weight in the target regolith at the Cabeus crater [8]. It seems likely that this water is ultimately derived from the impacts of comets with the lunar surface, although solar wind implantation and endogenic sources might also contribute. This is an important result, but the inferred quantity of water is sensitive to the calibration of the spectrometers on the LCROSS Shepherding Spacecraft, and a number of other assumptions (See the discussion by Colaprete et al. [8]). Ideally, therefore, this result needs to be confirmed by in situ measurements, and a penetrator-deployed volatile detection package would provide a means to achieve this.

In addition to ice in permanently shadowed craters, infra-red remote-sensing observations from the M³ instrument on *Chandrayaan-1* have found evidence for hydrated minerals, and/or adsorbed water or hydroxyl molecules, over large areas of the high latitude (but not permanently shadowed) lunar surface [50].

Surficial concentrations of up to 800 ppm (parts per million) OH and/or H₂O were inferred from the spectra. This OH/H₂O cannot exist as ice, and is more likely to be caused by the reduction of iron oxides in the regolith

by solar wind-implanted hydrogen, with OH/H₂O being retained in the cold high-latitude regolith. However, it is possible that, over time, this high-latitude OH/H₂O may migrate to polar cold traps and contribute to ice deposits there [11]. The concentration of this high latitude OH/H₂O with depth in to the regolith is currently unknown, and will require in situ measurements to determine. Again, penetrator-deployed instruments would be an efficient means of doing this.

Improved knowledge of the presence, composition, and abundance of water (and other volatiles) at the lunar poles is important for at least four reasons:

1. It is probable that the ice in permanently shadowed regions is ultimately derived from comet impacts. Even though the original cometary volatiles will have been considerably reworked by impact vaporisation, migration to the poles, and subsequent condensation, it remains possible that some information concerning the composition of the original sources will remain. Among other things, this may yield astrobiologically important knowledge on the role of comets in ‘seeding’ the terrestrial planets with volatiles and pre-biotic organic materials [7, 49].
2. Evidence for the creation, retention, migration, and destruction of OH and H₂O across the surface of the Moon with the lunar diurnal cycle is arguably one of the most important recent discoveries from the Moon. The processes involved are likely to be common on other air-less bodies, and quantifying them on the Moon will give us better insight into the volatile history and potential availability of water (ice) in the inner solar system.
3. As pointed out by Lucey [36], lunar polar ice deposits may be of considerable astrobiological interest, even if they do not preserve any vestigial information concerning their cometary sources. This is because any such ices will have been continuously subject to irradiation by galactic cosmic rays and, as such, may be expected to undergo ‘Urey-Miller-like’ organic synthesis reactions. Analogous reactions may be important for producing organic molecules in the icy mantles of interstellar dust grains, and on the surfaces of outer Solar System satellites and comets, but the lunar poles are much more accessible than any of these other locations.
4. The presence of water ice at the lunar poles, and even hydrated materials at high-latitude but non-shadowed localities, could potentially provide a very valuable resource in the context of future human exploration of the Moon (as a potential source of oxygen, rocket fuel and drinking water). Confirmation of its presence, and determination of its abundance, would therefore make a significant contribution to the developing Global Exploration Strategy of which renewed human exploration of the Moon is a key element [17].

Volatile detectors deployed on penetrators, and landed within permanently shadowed craters (and/or the surrounding non-shadowed but apparently nevertheless volatile enhanced areas), would be a powerful and economical means of determining whether or not scientifically and operationally valuable deposits of volatiles exist at the lunar poles. One of the implications of the

Table 2 Lunar science requirements

Number	Science requirement/success factor
1	To measure the size and physical state of lunar core
2	To determine the deep structure of the lunar mantle
3	To measure the thickness of the far-side lunar crust
4	To determine the origin of natural Moonquakes
5	To constrain the composition and thermal evolution of the lunar interior
6	To characterise the geochemistry at diverse lunar sites
7	To determine the nature and origin of lunar polar volatiles
8	To determine the presence and concentration of water ice in the permanently shaded craters (part of 7)

LCROSS and other recent spacecraft results is that such volatiles may be distributed very inhomogeneously in the lunar polar regions, and a penetrator mission would enable additional sampling of this distribution which would be important in terms of understanding sources/sinks of polar volatiles.

3.5 Science conclusions

Through deployment of a range of instruments (e.g. seismometers, heat-flow probes, X-ray spectrometers and volatile detectors) to diverse locations on the Moon from which geochemical and geophysical measurements have not yet been obtained (including the poles and the far-side), LunarNet penetrators have the potential to make major contributions to lunar science.

They will also provide knowledge (e.g. of lunar seismicity and polar volatile concentrations) that will be of central importance in the planning of future human missions to the Moon.

Furthermore, they can demonstrate a technology that will have wide applications for the exploration of other airless bodies throughout the Solar System (e.g. [22]).

A summary of the current lunar science requirements that can be addressed is given in Table 2.

4 Mission profile proposed to achieve LunarNet objectives

4.1 Mission design

The mission involves the delivery of a minimum of four penetrators into the lunar surface at widely dispersed locations. It is anticipated that one of the penetrators will be placed on the far side and at least one penetrator will be within a permanently shaded, polar crater. Therefore, direct communication between penetrator and Earth is not possible and a lunar polar orbiting relay

communications satellite (Orbiter) is required. The Orbiter will carry the four Descent Modules (DMs) into lunar orbit prior to their release.

Each Descent Module consists of a Payload Delivery System (PDS) and a penetrator. The penetrator includes both a scientific payload (see Section 5) and services (see Section 6). During the descent phase a camera (Penetrator Descent Camera) is used to provide impact site location and context information.

To meet the scientific objectives the following high level requirements have been placed on the orbiter, descent module and penetrators:

The orbiter shall:

- Carry the DMs into lunar polar orbit
- Release the DMs for descent to arbitrary locations on the lunar surface. Each DM shall be separately targeted.
- Provide a communications link (send and receive) between penetrator and Earth.

The descent modules shall:

- Provide continuous communications during descent
- Ensure penetrator impact as follows:
 - Impact within 2 km (tbc – to be confirmed) of specified location
 - Impact velocity $<300 \text{ m s}^{-1}$
 - Attack angle <8 degrees (angle between penetrator body axis and velocity vector)
 - Incidence angle <30 degrees (tbc) (angle between local vertical and velocity vector)
 - Impact spin rate <2 revolutions per second (around penetrator body axis)
- Measure impact location to an accuracy 100 m (tbc).

Each penetrator shall:

- Perform scientific investigations including sampling of the local regolith
- Communicate with orbiter during orbiter passages
- Operate for at least 1 year after impact

The Mission will comprise the following phases:

- Launch and transfer to a 100 km polar lunar orbit
- Deployment of penetrators (requiring temporary reduction of periapsis to <40 km for each release)
- Penetrator operations with orbiter at 100 km (1 year)

4.2 Launcher requirements

Launcher requirements are to deliver a lunar network of four stations using 51.6 kg descent modules, and supported by a communications orbiter. Since

the required mass is estimated to be 922 kg (see Section 5.6) a Soyuz 2–1b (Soyuz-Fregat) is baselined as the launch vehicle.

4.3 Orbit requirements

4.3.1 Transfer options

The main trade-offs in this area are the launch vehicle delivery orbit and the trajectory employed to reach the lunar vicinity.

Launch Vehicle Delivery Orbit This impacts both the subsequent trajectory and spacecraft design. The main options are releasing the spacecraft into a Highly Elliptic Earth Orbit (HEEO), such as a Geostationary Transfer Orbit (GTO), or inserting directly into a Lunar Transfer Orbit (LTO). The HEEO option is more efficient as the Trans-lunar Injection (TLI) manoeuvre is performed by the spacecraft and not the launch vehicle upper stage. This means an increased mass can be delivered to lunar orbit and the TLI can effectively be split into multiple smaller burns which are more efficient due to reduced gravity losses (effectively splitting the transfer into a series of intermediate orbits). However, a larger propulsion system (propellant volume) is needed on the spacecraft to perform this manoeuvre. The LTO option is slightly less efficient (the launcher upper stage has to accelerate its own mass and that of the spacecraft to achieve TLI) but will result in a more compact spacecraft design due to decreased propellant requirements.

Lunar Transfer Numerous transfer options from Earth to lunar orbit exist. With a direct transfer (as used by the majority of lunar missions to date) the spacecraft is placed on an elliptical transfer orbit to the Moon—either by its own propulsion system or by the launch vehicle upper stage as discussed previously. The main advantage of these trajectories is a short transfer duration (3–14 days), but they do require a high energy propulsion system. Other options include: a Weak Stability Boundary (WSB) transfer; a bi-elliptic transfer; and a low thrust spiral from an initial HEEO. From a preliminary assessment the direct transfer from an initial GTO orbit is baselined as this is a well understood trajectory which also maximises the available launch options. The overall delta-V can be minimised by selecting a number of phasing orbits before performing the final TLI manoeuvre. This approach has the added advantage of allowing gradual commissioning of the spacecraft and propulsion before performing the critical TLI and LOI manoeuvres.

4.3.2 Orbit options

Upon arrival in the lunar vicinity, the spacecraft will enter a ~ 100 km circular, polar parking orbit. From this orbit the spacecraft will temporarily manoeuvre into a DM delivery orbit (100×40 km). It shall then circularise into the parking

orbit before repeating this process for the remaining DMs. This ensures that any point on the lunar surface is potentially accessible to the penetrators.

A nominal deployment altitude of the Descent Modules of 100×40 km, together with slight modifications to these altitudes can be investigated (in conjunction with the other two above mentioned studies—penetrators and descent systems) to ensure that an optimal set of delivery conditions is achieved. For example, the most suitable propulsion system for the PDS may require a slightly lower delivery orbit to ensure that the drop altitude is compatible with the maximum penetrator impact velocity of 300 m s^{-1} . In addition, telemetry must be relayed back to the orbiter from the DM during its descent to the surface.

4.4 Ground segment requirements

Two ground stations would be suitable for LunarNet: e.g.:

- SSTL (Surrey Satellites Technology Limited) (RAL Antenna): Lat: 51.5° ; Long: -1.3°
- South Point (Hawaii): Lat: 19.0° ; Long: -155.7°

The ground stations will be required to provide communications with the orbiter. This will include commanding for orbiter orbit and attitude changes; descent module release operations (nominally four per mission, spaced, for example, once every 2 weeks); and any non-nominal commanding. The ground stations will also be required to receive downlinked orbiter health and safety data, and penetrator science data.

The ground stations will also be required to provide commands to the individual penetrators via the orbiter. Such commands are needed to optimise the operation and data return from the payload. An externally referenced time signal is needed for operation of the seismometers to form a network.

A single Penetrator Control Centre (PCC) will be created to monitor the health and performance of all penetrators, and to provide level 1 data products to the various instrument teams—who will perform downstream data analysis within their institutes.

4.5 Critical issues

While technological solutions are available for all mission aspects, the following are considered to be the most critical:

- That the Penetrator Delivery System ensures a survivable attitude/velocity at impact
- That the impact sites are chosen and characterised appropriately
- That low temperature operation within permanently shaded craters can be sustained for >1 year.

5 Proposed model payload to achieve the science objectives

Described here are the various payload instruments—both as a baseline set and with additional options. The penetrator itself, along with services including power, thermal control and command and data management, is described further in Section 6.

The study of a penetrator for a Jovian Icy Moon commissioned by ESA included the preparation by ESA of a Payload Definition Document [19] and much of the information included in this section is taken from this document which was itself compiled using inputs from many of the proposers of Lunar-Net. Values given here have also been updated by consortium members from recent studies.

5.1 Overview of all proposed payload instruments

All proposed payload instruments are described in Table 3.

The Model Payload instruments are discussed in more detail below. Note that a sample acquisition system is also described since this is necessary for the Mass Spectrometer and would also be of value to other instruments.

5.2 Accelerometer

The main goals of this experiment are:

- To derive mechanical properties of the lunar regolith vs. depth. Important in its own right and to give context to the geochemistry and geophysical measurements.
- To determine the depth below the surface at which each penetrator comes to rest and so provide important information for the interpretation of results from other experiments, including heat flow.
- To provide a full dynamic history of each penetrator impact, for comparison with results from ground testing and simulations.

5.2.1 Description and key characteristics

Two sets of 3-axis accelerometers will need to be located inside the penetrator close to its axis of symmetry. One set shall be mounted close to the penetrator tip, the other close to the penetrator's rear (upper) end. This is to derive the complete motion history of the penetrator (position and orientation) and compensate for the mechanical response of the penetrator structure. Accelerations of up to $\sim 15,000$ gee can be expected during impact. The Endevco Model 7270A-60K Piezoresistive accelerometer is baselined as shown in Table 4.

The electronics circuit design would use the Huygens HASI Accelerometer PZR design, with a resistor value changed to modify the circuit gain. This uses an Analog Devices AD524 precision instrumentation amplifier. The

Table 3 All proposed penetrator payload instruments

Instrument	Acronym	Mass [kg]	Volume [cm ³] (Size cm)	Power [W] (Energy [W h])	Total Data Volume [kbit]	Technical Readiness Level (TRL) Heritage ^a
Proposed model payload						
Accelerometer (8 sensors)	ACCL	0.07	2.4	0.8 to 1.2 (0.17)	1 Mbit	TRL 6–8 Off-the-shelf components, Lunar A, Pendine
Descent camera	DC	0.160	9 (3 × 3 × 3)	0.160 (0.015)	~ 10 Mbits after compression Max: 0.5 Mbit	TRL 7+ general camera technology TRL 2 for proposed design
Heatflow probe	HEAT	0.300	20	0.025 to 0.3		TRL 7: Lunar A (Mounting will be specific to mission)
Magnetometer	MAG	0.07	200 (10 × 10 × 2)	0.15 - 0.4	~ 1 Mbit(0.06 kbps)	TRL 5: Pendine trials
Mass Spectrometer	MSPC	0.75	1000 (10 × 10 × 10)	3–6	~ 0.2 Mbits	TRL 4/5: Rosetta/Beagle2
Seismometer	SEIS	0.3	200	0.053 to 0.112 (500)	~ 5 Mbit (720 bps)	TRL4–5: Netlander and ExoMars developments, Pendine Trials
Engineering Tiltmeter	ETLT	0.010	25	0.1	1 kbit	TRL 6–8, Huygens, Mars 96
Water/Volatile Detector	BIOC	0.750	1000	3	TBD	TRL 4–8: DS-2, Huygens, ExoMars, Pendine
X-Ray Spectrometer	XRS	0.260	160	4 (24)	0.1 Mbits	TRL 7: Mars 96
Potential additional instruments	PERM	<0.1	TBD	0.5	1 kbit	Rosetta (Sesame-PP)
Dielectric/permittivity sensor	MPH	0.004(TBC)	2.6 × 1(TBC)	TBD	(0.46/s)(TBC)	Huygens, Rosetta (Sesame-Casse)
Microscopic Imager	MICI	TBD	TBD	TBD	TBD	MoonLITE
Radiation Monitor	RADM	TBD	TBD	TBD	TBD	Huygens
Radio Beacon	RBEC	0.4	TBD	4 W		
Thermo-gravimeter	THERMO- GRAV	40	(4 × 2.5 × 3)	0.5 to 2	~ 4 Mbit	TRL 4–5, Rosetta, Marco Polo

^aPendine refers to UK penetrator trials (see [56])

Table 4 Endeveco accelerometer parameters

Range	$\pm 60,000$ gee peak	Over range limit	$\pm 180,000$ gee
Sensitivity	3 micro-V/g typically	Warm Up Time	2 min (max), 15 s (typical)
Response	0 to 100 kHz (at $\pm 5\%$)	Operating temperature	-34°C to $+66^{\circ}\text{C}$
	0 to 136 kHz (at ± 1 dB)	Storage temperature	-54°C to $+121^{\circ}\text{C}$
Transverse sensitivity	5% max	Materials	Stainless Steel (17–4 PH CRES) Stainless Steel (17–4 PH CRES)
		Weight	1.5 g

accelerometers will be mounted internally, with axes aligned with those of the penetrator.

5.2.2 Instrument performance

Precise determination of the penetrator motion and final depth requires each of the accelerometers to have range, sensitivity, noise, offset performance and frequency characteristics that are compatible with the impact event. For 3 mm spatial resolution at an impact speed of 300 m s^{-1} , a sampling rate of 100 kHz is required.

5.2.3 Operations

The accelerometers will operate during the impact event, sampled rapidly enough to achieve sufficiently fine spatial resolution of the motion. Such measurements are routine in military applications. While the accelerometer might be operational for up to 10 min prior to impact, by using a 0.1 s circular buffer the amount of data recorded and transmitted would be kept to <1 Mbit.

5.2.4 Heritage and technology readiness level

TRL 8. COTS (Commercial Off The Shelf) accelerometers are available from companies including Endeveco (e.g. model 7570A flown on DS-2), Kistler and Brüel, and Kjær.

5.3 Descent camera

5.3.1 Description and key characteristics

The Descent Camera does not have to withstand impact and so general space qualified camera technology will be suitable. For this the space qualified Beagle-2 PANCAM (Panoramic Cameras) which are also in development for ExoMars are acceptable with 160 g and 900 mW resource requirements [24]. However, a lower mass system based on a ‘camera on a single chip’ 3 Mpixel CMOS detector coupled to a 45° objective lens (1/3” format) via

minimal encapsulating structure, is additionally proposed as an advantageous alternative.

The optical axis shall be aligned within 1° of the penetrator axis. The camera would be radiometrically calibrated to better than 1% and geometrically calibrated so that the relative alignment of the optical and penetrator long axis is known to better than 0.1° .

5.3.2 Instrument performance

Expected camera performance (based on a COTS mobile phone camera module) is shown in Table 5.

5.3.3 Operations

The camera will image the surface in RGB colour from 40 km down to ~ 1 km altitude to determine landing site location and context; thus supporting the achievement of the science objectives. Below 1 km the image blur due to motion exceeds the camera resolution.

The camera will interface directly with the penetrator DHU (Data Processing Unit), transferring up to 32 Mbit bits per image. Therefore, 4 images acquired during the 3 min 42 s decent would require 128 Mbit of uncompressed storage. Binning (2×2 or 3×3) could be performed in the DPU to reduce the data volume, and a further reduction by a factor of 15 through lossy compression (e.g. wavelet). The baseline value of data volume from a single camera image is 10 Mbit.

5.3.4 Heritage and technology readiness level

Optical cameras for use in space are relatively common-place (certainly $TRL > 7$) which could be employed here with modest use of resources, though we would aim to space qualify the lower mass and power COTS mobile phone camera modules for which the TRL is currently ~ 2 .

5.4 Heatflow probe

For measuring planetary heat flow, two parameters are required, namely: the subsurface thermal gradient and the thermal conductivity of the subsurface

Table 5 Descent camera parameters

Size ($l \times w \times h$) (mm)	$10 \times 10 \times 30$	Linear resolution (m/pixel)	120 at 40 km, 3 at 1 km
Array size ($w \times h$) (pixels)	512×512	Pixel size	$2.2 \times 2.2 \mu\text{m}$
Output format (bayer matrix)	10 bit RGB	Angular resolution	0.3 mrad/pixel
Signal to noise ratio (dB)	42	Spatial resolution	0.3 m at 1 km
Diagonal field of view ($^\circ$)	45	Drive voltage	2.8 V
Sensitivity ($\text{DN/s}/(\text{W/m}^2 \cdot \text{str.}\mu\text{m})$)	168	Dynamic range	50 dB

material (i.e. the regolith). The heat flow experiment will measure the temperature gradient in the lunar regolith by using temperature sensors on the outside of the penetrators. These will be accommodated at several locations between nose and tail. The thermal gradient can be determined from temperature measurements once the orientation of the penetrator is known from the tilt meter. A correction will have to be made to deduct the thermal effect of the penetrator from the temperature measurements. The thermal conductivity of the subsurface regolith will be measured in four locations using small plate heaters.

5.4.1 Description and key characteristics

The heat flow experiment will consist of a number of sensors located on the outside of the penetrator together with electronics (100 g). These are in detail:

- a suite of eight relative temperature sensor (thermocouples) on the outside of the penetrator (each 12 g)
- four absolute temperature sensors (Pt-100 or NTC thermistors) on the outside of the penetrator (each 12 g)
- four miniature thermal conductivity sensors (e.g. heater plate with thermocouple, or miniaturized needle probe) (each 20 g)

5.4.2 Instrument performance

The feasibility of a penetrator-based heat flow experiment has been studied in detail (e.g. [62]). Based on thermal sensors with an accuracy of 0.01 K, Tanaka et al. [61] estimated an accuracy of 10% for the gradient measurement. Using plate heaters, thermal conductivity can also be measured with an accuracy of 10%. Needle probes increase this accuracy into the 1–2% range. Parameters for Heat Flow instrument are given in Table 6.

5.4.3 Operations

Temperature sensors: temperature measurement $\sim 1/h$, < 0.1 Mbit data volume.

Thermal conductivity sensors: temperature measurement (low power) and thermal property measurement (high power), 50 Hz during measurement, < 0.5 Mbit data volume.

Table 6 Heat flow instrument parameters

	Heat flow
On-board data handling (OBDH)	Temperature measurement: e.g. 1/h > 18 bit resolution, depending on chosen sensor.
Telemetry	Thermal property measurement: 50 Hz, 12 bit resolution < 0.5 Mbit for thermal property < 0.1 Mbit for temperature

5.4.4 Heritage and technology readiness level

COTS space qualified NTC thermistors are available e.g. from Betatherm (<http://www.betatherm.com> accessed 25 March 2011). Thermal sensors based on Lunar-A flight heritage: TRL 6.

The heat flow experiment on board the JAXA-ISAS Lunar-A penetrators had flight readiness level.

5.5 Magnetometer

5.5.1 Description and key characteristics

The magnetometer will measure the three components of the local magnetic field vector in the vicinity of the penetrator in the bandwidth DC up to a maximum of 10 Hz (i.e. 20 samples per second). It consists of (at least) two tri-axial Anisotropic Magneto-Resistive (AMR) sensor heads connecting to a single card housing associated drive and signal conditioning electronics and a bus communication element (See Fig. 3). AMR sensors are proposed instead of the more traditional fluxgate design implementation due to the much lower mass and volume (as well as superior robustness against high impact) of the MR device while demonstrating broadly equivalent performance of a fluxgate core of equivalent volume.

The sensors and electronics card are assumed to be wholly contained within the penetrator shell. Centralised power and data handling is assumed via a common backplane connection. The sensor heads should be located in a region of the penetrator that is far away from magnetic disturbing sources and will connect to the magnetometer electronics via an ultra-light harness. The use of two (or more) sensors fitted at multiple positions within the penetrator will permit determination of the local penetrator background stray field thereby allowing separation of this perturbing signal from the scientific signal. Driven closed loop electronics are used to extract an analogue measure of the magnetic field.

Critical issues exist with respect to instrument calibration (for a sensor wholly enclosed within the penetrator shell) and absolute recovery of the

Fig. 3 Magnetometer

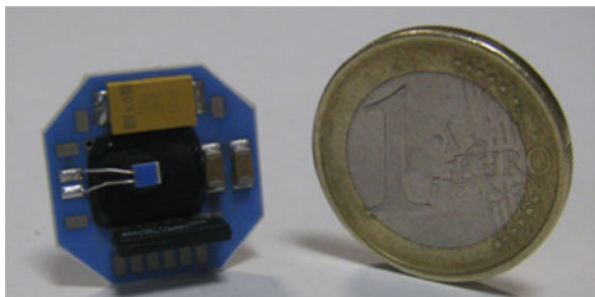

magnetic vector direction post impact, due partly to the difficulty of acquiring knowledge of the azimuthal position of the impacted penetrator and partly due to the lack of sensor rotation after impact. Calibration will rely primarily on use of comparisons with lunar field maps/models together with in-situ data from a presumed orbiting magnetometer. The magnetometer sensors should be aligned along an axis within the penetrator with a knowledge and stability of 1° .

5.5.2 Instrument performance

The sensor is relatively low noise $100 \text{ pT}/\sqrt{\text{Hz}}$ above 1 Hz and the instrument range would be set to $\pm 1200 \text{ nT}$ with 50 pT digital resolution. The standalone instrument accuracy would be $< 10 \text{ nT}$ although this figure would improve to around 2 nT if the orbiter includes a high accuracy fluxgate vector magnetometer. Indicative resources are less than 5 g for the sensor and 50 g for electronics. Power consumption would be 0.15 W average and 0.4 W peak.

5.5.3 Operations

A 2 Hz cadence would require a data rate of 60 bits per second. The magnetometer instrument requires only a small number of operating modes, and could be limited to power-on/power-off commands, and data rate commands, if required.

5.5.4 Heritage and technology readiness level

The sensors would be of similar design to those currently under development for the Trio-Cinema mission (a three spacecraft CubeSat constellation in LEO (Low Earth Orbit) due for launch in 2011) and originally targeted for the UK MoonLITE mission. The design is currently at TRL5. Additionally AMR sensors of the type described above successfully survived the MoonLITE impact test firings in 2007.

5.6 Mass spectrometer

The measurement of volatile content in the lunar regolith (both at polar and non-polar regions) is a key mission objective. The Lunar Evolved Volatile Ion Trap Analyser (LEVITA) is an instrument which through the identification and quantification of the volatile constituents in the lunar surface and subsurface aims to address outstanding questions regarding the distribution, origin and transportation of volatiles in the lunar system. The rationale for LEVITA is that the mass spectrometry analysis of evolved volatiles at penetrator impact sites will allow detection of volatiles and determination of their origin through isotopic analysis, and potentially the detection of other organic compounds to be found on the Moon.

5.6.1 Instrument description and key characteristics

The mass spectrometer system (See Fig. 4) is based on the miniature state of the art quadrupole ion trap mass spectrometer used within the UK Ptolemy instrument on-board the ROSETTA lander Philae. This is a powerful yet simple device into which neutral gases are introduced into a cavity formed by three hyperbolic electrodes to which are applied suitable radiofrequency fields. A cold-cathode Field Emission Device (FED) is used to introduce electrons into the cavity to effect electron-impact ionisation of the gas molecules, and the resulting ions may become trapped within stable orbits within the cavity. Once trapped the ions are manipulated to fall upon an external electron multiplier detector to produce mass spectra yielding information about the chemical and isotopic identities and abundances of the gas molecules.

Neutral volatiles are evolved from the sample material by either heating in a miniature oven, heating by a stand-off laser device or heating caused by thermal losses from the penetrator (in polar regions). The primary mode of operation relies on heating of samples within ovens. The oven is resistively heated, which liberates neutrals from within the sample in a stepwise manner. Stepped heating is an established technique which is commonly used to analyse extra-terrestrial materials. The temperature of each step is chosen to sequentially release more refractive components from the sample mixture, thus effecting a degree of separation before the released materials are further analysed in the mass spectrometer. Additionally, a calorimetric analysis method is incorporated into the heater oven. During the heating period, the power consumption required to achieve a pre-programmed heating ramp rate will be monitored, and thus the energy associated with phase changes in the sample will be reflected in the power profile.

The use of an oven requires a mechanism capable of delivering a sample into the oven and then sealing the oven. A de-scoped option would be to heat sample material on a simple hot-plate, though with this arrangement

Fig. 4 Mass spectrometer

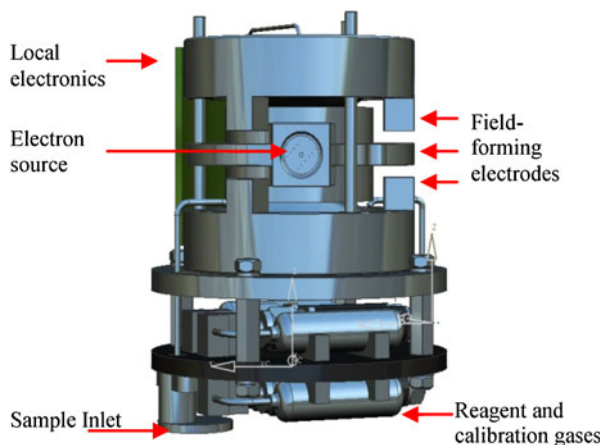

lower sample temperatures would be achieved for a given amount of heating power. A number of types of analysis are possible depending on the available resources. These include:

- Stepped heating/pyrolysis to evolve volatile components from the sample
- Analysis of isotopic composition of released water (i.e. D/H (Deuterium to Hydrogen) ratio) through use of on-board reagent gas
- Analysis of organic material
- Combustion (one step) of organic material with oxygen at 500°C

An alternative heating method employing miniature, high powered solid state laser diodes could be used for material outside the penetrator body, either in a direct line-of-sight through an aperture in the penetrator body or via a deployable fibre optic cable. This approach might avoid the need for sample acquisition and requires further study. Finally, the presence of the penetrator will affect the local thermal environment resulting in an increase in the volatile sublimation rate which can be monitored. Operating the instrument in a ‘background sniff’ mode may give a contextual measurement to aid interpretation of results from other instruments, e.g. to provide an understanding of changes in the external environment caused by the impact event and penetrator presence.

The calibration system comprises a number of miniature gas volumes containing reference and processing gases. These pressure vessels are sealed with in-house developed and patent-pending miniature high performance, high pressure valves which control the flow of gases to the mass spectrometer, allowing in-situ instrument calibration and sample processing.

5.6.2 Instrument performance

Instrument objectives are:

- Determination of surface compositions and chemistry, through the characterization of the volatile content of surface and sub-surface material
- Measurement of the isotopic composition of organic material (D/H) to infer origin i.e. local or meteoritic.
- Determination of the organic compounds present.

The performance parameters for the mass spectrometer to achieve the above objectives are given in Table 7.

Table 7 Mass spectrometer parameters

Parameter	Value	Comment
m/z range	10 – 300 Da	molecular species from H ₂ O (~m/z 18) to organic molecules up to m/z 300
Mass resolution	Unit resolution i.e. >18 at m/z 18; >200 at m/z 200 etc	Baseline requirement.
Sensitivity	Sample size: 100 mg	

5.6.3 Operations

The following Science Modes have been identified:

Initialisation Bring the instrument from a thermal cold start to operation temperature in preparation to start a science sequence. Heaters will be commanded to heat the mass spectrometer and parts of the system that come into contact with sample. Valves will be actuated to bring the required sub-systems up to pressure.

Background scan Performs a background mass spectrum without sample. The background scan is essentially a diagnostic of out-gassing and off-gassing in the region of the penetrator and will allow volatile out-gassing of surface and sub-surface material surrounding the penetrator to be monitored over time as it warms up due to the presence of the penetrator.

Reference scan Performs an in-situ calibration of the mass spectrometer with the on-board reference gas. The mode actuates and controls the flow of reference gas into the mass spectrometer cavity whilst a mass spectrometer scan is performed.

Oven sample Requiring heater control, reference gas and pre-processing gases

Laser sample The laser diode is run in constant power mode for a number of seconds to heat sub-surface material.

5.6.4 Heritage and technology readiness level

This instrument draws heavily upon, and be developed by the team responsible for, the Ptolemy gas chromatograph isotope ratio mass spectrometer/evolved gas analyser currently en-route to comet Churyumov–Gerasimenko aboard ROSETTA.

5.7 Seismometer

5.7.1 Description and key characteristics

The microseismometer elements are MEMS-based (Micro-Electro-Mechanical Systems). A micromachined silicon suspension is used as the sensing element. This acts as a spring/proof-mass system, converting any external vibration to a displacement of the proof mass. This displacement is measured using a position transducer which consists of a series of electrodes on the proof mass and fixed frame forming a capacitive transducer together with sensitive readout electronics. The signal passes through a feedback controller and transconductance amplifiers to produce currents in a series of coils which

form parallel electromagnetic actuators to maintain the position of the proof mass. There are two feedback loops, one producing the signal, and the second producing low-frequency integral control. One further coil is used to produce actuation from an external calibration signal.

Figure 5 shows the silicon suspension of the microseismometer fabricated at Imperial College, London. The suspension is formed by cutting through the 500 μm thickness of a silicon wafer, using deep reactive-ion etching (DRIE). The clean profiles evident in the 30 μm -wide flexures are the result of a concerted programme of DRIE optimization [52]. In addition, the dynamics of the suspension are optimized to produce very good rejection of off-axis modes [51].

The capacitance displacement transducer is of a novel design [53]: the moving electrodes on the proof mass are in the form of an array which moves laterally over a similar array of fixed electrodes on the glass capping plate with the motion of the proof mass. Hence as the electrodes move in and out of registration with proof-mass motion, a periodic cycling of the capacitive coupling occurs. Optimization of the design for this lateral capacitive array transducer, including the effects of stray capacitance, has been carefully studied and verified [46].

Finally, a magnetic circuit is mounted either side of the sensor-head sandwich. This provides the magnetic field for the feedback actuator. This circuit has been designed and modeled by finite element analysis, and tested against the modeling to better than 90% agreement. The circuit consists of four rare-earth, rectangular magnets, four pole pieces and two soft-iron yokes which close the circuit.

Ruggedization against impact will be accomplished through the use of a high purity, volatile potting material that sublimates after deployment [27]. This technique is of particular interest in lunar deployments as the Moon's vacuum can be readily applied to the sublimant by incorporating a seal that is broken on impact. Both for sublimant removal, and to maximize mechanical coupling,

Fig. 5 The silicon suspension of the microseismometer. The die is 20 mm²

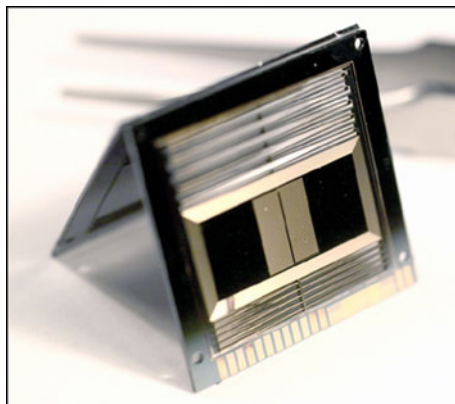

the microseismometer sensors should be located external to any vacuum vessel used for thermal control.

In order that the components of the Moonquake-induced vibration map sufficiently to the axes of the microseismometer, the vertical axis, and hence deployment, should be aligned to better than 10° to the lunar surface normal. This requirement is only applicable during single, vertical-axis, operation. There is no absolute requirement on the azimuth, but knowledge of the azimuth will allow for complete vector determination of the vibration.

5.7.2 Instrument performance

The requirements for a seismic investigation of the Moon (Table 8) are based on data recorded during the Apollo programme and led to a need for: low-noise; high-sensitivity; well-coupled to source signals; isolated from ambient noise; broad bandwidth; three matched components; long operating time; and linearity [28]. The microseismometer performance target is shown in Fig. 6. This matches or exceeds the published ILN requirement above 1 Hz for a short period seismometer suitable for a network deployment.

5.7.3 Operations

Global network mode One-axis operation triggering 3-axis operation when a seismic event is detected. Lunar seismic events from Apollo showed that events had durations of up to 10 s of minutes and gave stronger signals in the horizontal axes compared with the vertical axis. This is typical for the Moon but unlike the Earth where the vertical axis normally dominates. It is therefore proposed to use a horizontal axis trigger. The S-P (Secondary-Primary wave) travel times of the phases are typically more than 100 s [34, 43] which implies a requirement to initialize the other axes within that time – the microseismometers will have an initialization time of 30 s.

Full operation mode Three-axis operation. For local seismic events the time-lag between axes will be less and so it is proposed to operate a higher power mode in which all axes are continuously active. To conserve power this mode will operate for one month at the beginning of the mission in order to characterize the local seismic environment. For the remainder of the mission the microseismometer will operate in a power-saving, ‘global network mode’.

Table 8 Microseismometer performance

Parameter	Requirement
Noise	$<0.5 \text{ ng}/\sqrt{(\text{Hz})}$
Bandwidth	0.03 to 80 Hz
Temperature coefficient	100 ppm full scale/K
Nonlinearity	$<1\%$ full scale
Range	0.05 gee

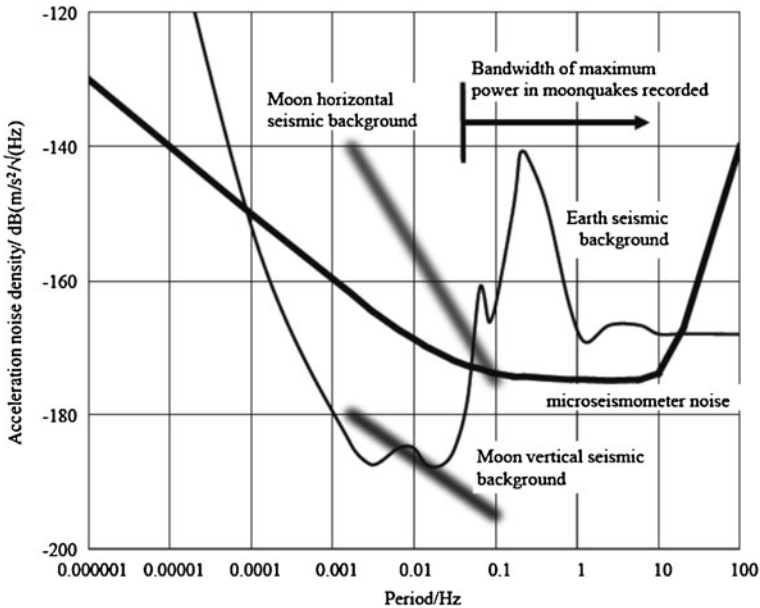

Fig. 6 Comparison of the microseismometer's noise performance to horizontal and vertical axis background lunar seismicity measured during Apollo as calculated by Lognonné and Johnson [35], and the Earth's background seismicity as determined by Peterson [48], (after [70])

Sampling will be 10 samples per second (with 24 bits per sample) with frequencies up to 4 Hz, which covers most of the frequency range of Moonquake energy. The baseline on-board data compression will be lossless and achieve an approximately three-times data volume reduction. For short periods a higher rate mode can be considered (200 samples per second).

5.7.4 Heritage and technology readiness level

The microseismometer has been under development for a series of planetary missions, including Netlander, ExoMars and MoonLITE. Although evaluated by ESA at a TRL of 5 for ExoMars, the additional impact survival requirements reduce that to an estimated current value of 4.

5.8 Water/volatile detector

The measurement of volatile content in the shaded, polar lunar regolith is a key mission objective and so in order to provide unequivocal results, whilst ensuring redundancy in this key area, an integrated suite of complementary instruments is proposed. Analysis techniques and sample requirements are listed in Table 9. The description of a mass spectrometer is considered separately in Section 5.6, and the associated sample acquisition in Section 5.11.

Table 9 Water and volatile detection techniques

Technique	Method	Sampling requirements
Mass spectrometry	Direct	Sample ingress/laser stand-off
Spectroscopic	Direct	Sample ingress
Mutual impedance spectroscopy	Inferred	Touch sensor
Pressure sensor	Inferred	Sample ingress
Calorimetric	Inferred	Sample ingress

Note also that in situ measurement of regolith electrical properties are needed for interpretation of ground penetrating radar results from orbit.

5.8.1 Description and key characteristics

Mutual impedance spectrometer Laboratory studies of lunar simulants have shown that a measurement of mineral dielectric constant is a suitable method of detecting water to levels of 0.1% (with possible lower detection limits of 0.001%). The sensors are physically small, simple devices and can be incorporated into the drilling mechanism, thereby allowing in-situ measurements.

Calorimetric analyzer The sample heater will be programmed to deliver a stepwise heating profile to elevate the collected regolith material to above the sublimation point of ice, hold it there for a pre-determined time before turning the heater off and allowing the sample to cool. During the heating-and-hold period, the recorded temperatures and power profile will reflect sample cooling i.e. when ice sublimates more energy is required to maintain the programmed heating ramp so the presence of ice can be detected in the power profile of the heating cycle.

Pressure sensor As the stepped heating profile is implemented, evolved gases expand into the analysis chamber and re-freeze when the heater power is switched off. The resulting pressure increase/decrease will be measured by a MEMS pressure sensor. The presence of water (and other volatile) ice will be detected in the temperature-pressure profile during sample heating and cooling.

Optical detection system As the stepped heating extraction is conducted, evolved gases will expand into the analysis chamber. Spectroscopic analyses are conducted using tuneable diode laser scanning across a single water line in the 1.37 μm region of the spectrum. The water vapour abundance in the chamber is calculated using Beer's law [37]

5.8.2 Instrument performance

Instrument performance will depend on the selected technologies described above.

5.8.3 Operations

A sequence of measurements (including mass spectrometer and sample handling) is foreseen involving: Pre-impact checkout; Post-impact checkout; Sample collection (drilling); Sample control (heating); Water detection 1 (Mutual impedance spectrometer); Water detection 2 (Heating/temperature); Water detection 3 (pressure/optical); Water detection 4 (mass spectrometer).

5.8.4 Heritage and technology readiness level

The pressure sensors are devices which are in use on the Ptolemy instrument onboard Philae—the Rosetta Lander [72] and have TRL 8. The heritage of the optical detection system is based on the laser detection system which flew on the NASA Deep Space 2 instrument [58], and consequently has TRL 6/7. The impedance spectrometer is based on a proven mutual impedance probe which has been demonstrated on instruments flown on Philae [54, 64] and Huygens [16] spacecraft at TRL 8. The subsurface element is based on mutual impedance probe being considered for mole deployment [57] at TRL 4 and can be expected to increase as part of the HP3 instrument development for ExoMars.

5.9 X-Ray spectrometer

5.9.1 Description and key characteristics

The aim of the geochemistry element is to greatly improve our understanding of global lunar geochemistry by performing in-situ analyses at globally dispersed sites, and to provide contextual information for related payload elements such as the Polar Volatiles detector and accelerometer. The requirement is therefore for one or more techniques that can detect and quantify the major rock-forming elements Mg, Al, Si, Ca, Fe, and Ti.

The selected technique is X-ray spectrometry, for which the Beagle 2 X-ray Spectrometer (XRS) provides the benchmark. Primary excitation was provided by two ^{55}Fe (emitting X-rays of 5.90 and 6.49 keV) and two ^{109}Cd sources (emitting X-rays of 22.16 and 24.94 keV). The fluorescent X-rays are detected by a Si PiN detector. The instrument utilises excitation from radioisotope sources, identical to the Viking landers XRS, but uses the solid state detector employed by the APXS (Alpha Particle XRS) on Pathfinder. The instrument is sensitive to X-rays in the 1–27 keV range and the corresponding range of detectable elements is from Na to Nb.

The baseline XRS is based on the Beagle 2 instrument and comprises two parts: the Detector Head Assembly (DHA) and the Back End Electronics (BEE). The XRS will view the sample of lunar regolith brought into the penetrator volume by the micro-drill. Alternatively, a small x-ray transparent window with shutter could be provided in the rear wall of the penetrator.

Selection of appropriate technology will depend upon the method selected for analysing the external material (whether employing a remote stand-off technique, or ingesting a sample into the penetrator, and the volume of that sample).

5.9.2 Instrument performance

The XRS can expect to achieve accuracies of 5–10% for major and trace elements and reach detection limits of ~10–30 ppm for trace elements including Rb, Sr and Zr [63].

5.9.3 Operations

A baseline will be to accumulate spectra for two different periods of 3 hours of 50 kb/spectrum.

5.9.4 Heritage and technology readiness level

Heritage for penetrator-borne XRS is provided by the ANGSTREM instrument in the aft-body of the Mars 96 penetrators. The LunarEX penetrator benefits from Beagle 2 heritage. Hence we assign TRL = 7 but must bear in mind that the instrument will require qualification at high-g levels.

5.10 Tilt meter

5.10.1 Description and key characteristics

The goal of this experiment is to determine the angle from the local vertical at which each penetrator is tilted. This is needed to determine the orientation of the seismometer axes and to help measure the vertical temperature gradient for the heat flow determination. A number of solutions are possible including a device from the Taiko Device Group (Japan), which originates from automotive applications but was space qualified for use in the *Lunar-A* penetrators. For each axis a cylindrical cell is part-filled with a dielectric liquid and its level detected capacitively by electrodes on the circular faces. Other possibilities include a Spectron L-series device, as used by The Open University group on *Huygens* and the *Mars 96* penetrators (See Fig. 7), an Analog Devices ADXL320, and a two-axis electrolytic inclinometer (e.g. from Fredericks Company).

The tilt sensors will be mounted internally, with axes aligned with those of the penetrator.

5.10.2 Instrument performance

The tilt meter will measure the attitude of the penetrator to better than 0.1°.

Fig. 7 Mars'96 tilt meter

5.10.3 Operations

The tilt meter will be operated to provide 1 Hz sampling of 12 bits resolution for the first minute after impact, then a few times per lunar day thereafter.

5.10.4 Heritage and technology readiness level

Current TRL is 6–8 depending on the choice of sensor.

5.11 Sample acquisition

The present baseline penetrator payload includes a requirement for sample acquisition. This can be achieved either through passive (such as a scoop) or active (such as a drill) means. In fact, options to achieve all mission goals without sample acquisition (through local remote sensing) are also to be evaluated. In this proposal we baseline a sample acquisition drill mechanism.

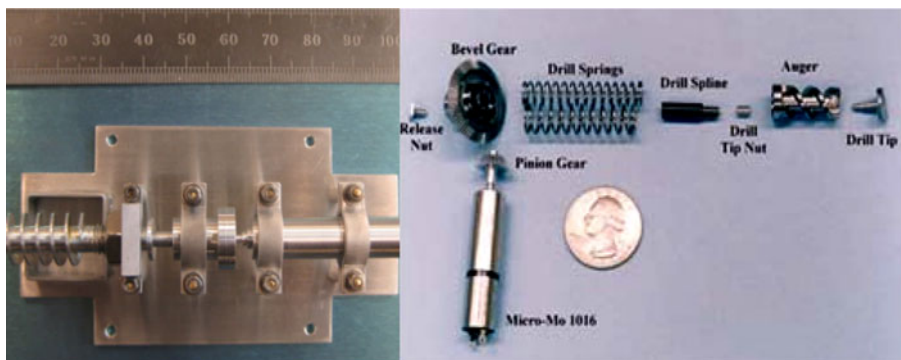

Fig. 8 Left: SSC micro-drill at 1st Pendine impact trial [56]; Right: DS2 probe drill (<http://nmp.nasa.gov/ds2/tech/sample.html> accessed 25 March 2011)

5.11.1 Description and key characteristics

The major components of an active sampling mechanism include an electric motor, gearbox, drill string and drill bit. The release/withdrawal mechanism of the drill string is key to the design. Possible solutions include using a driven screw or loaded spring. Figure 8 shows two drill prototypes for active sampling. The micro-drill developed at the Surrey Space Centre (SSC) uses a screw-driven method whereas the DS2 drill used a loaded spring.

Instrument design The current baseline design for technology development is to use an active sampling approach and build upon the SSC micro-drill concept, which provides a simple and mechanically robust solution to acquire a sample. It has high controllability and can support collection of multiple samples in comparison to any passive methods. The basic structure of the first SSC micro-drill prototype survived the 1st Pendine impact trial [56] and has since been further improved.

Drill Assembly This consists of the drill bit, drive mechanism, and an electric micro-motor, as well as mountings to the penetrator compartment (see Fig. 9). The latest SSC micro-drill prototype has a modified mounting relative to the original design, since this is where the main failure occurred during the Pendine impact trial. Also, the screw-drive mechanism has been enhanced by adding a spring driven function which allows the drill to chip away at hard materials, without becoming jammed.

Outer shell penetration will be achieved either by drilling through a plug or using a door/flap/iris mechanism.

5.11.2 Instrument performance

The current requirements are summarized in Table 10.

Prototype build and testing with a lunar soil simulant at SSC involved a SAS (Sample Acquisition System) mass of 79.9 g which includes micro-switches and wiring, with dimensions of $90 \times 25 \times 20$ mm. The average operating

Fig. 9 Drill assembly



Table 10 Sample acquisition parameters

Sample collection per deployment	~ 200 mg
Number of sampling	≥ 1
Sampling distance	1–2 cm from the shell
Mass	~ 50 g
Power	1.5 W peak during operation
Dimensions:	Within one payload compartment which can be shared with another instrument.
Working temperature	70 K
Operation duration per sampling	In the range of a few minutes
Controllability over sampling (e.g. time, speed, sample quantity, location, etc)	High

power during sampling was 0.64 W with a peak of 1.19 W. The average sample collection per deployment was 336.8 mg (± 20 mg) while the average time for sample collection, including withdrawal of the drill, was 15 ± 1 s. The sampling distance was 1 cm. From this the total power usage during sample acquisition is estimated to be ~ 0.003 W h.

5.11.3 Operations

At minimum the drill will be required to access one sample, though is designed for repeated operations as may be required to access e.g. deeper material.

5.11.4 Heritage and technology readiness level

A similar drill was flown on Deep Space-2 (TRL 6). The SSC design is currently at TRL 3–4, parts having been tested during the Pendine trial and within the laboratory.

5.12 Proposed procurement approach

It is proposed that the penetrator together with its payload be provided from national agencies. The various payload elements will be procured from collaborating instrument consortia. The baseline proposed here is an exemplar based on the current state. Actual procurement will be a mixture of COTS (Commercial Off-The-Shelf) acquisitions (e.g. Accelerometer) and bespoke developments (e.g. Micro-seismometer, Mass Spectrometer, Sample acquisition). The majority of payload elements will come from international consortia and expertise in penetrator technology is available within Europe, the USA, Japan and Russia. Canada and China have also instigated penetrator research and development programmes.

6 System requirements and spacecraft key issues

6.1 Basic spacecraft key factors

One lunar orbiter spacecraft is required to carry the four descent modules. Each descent module consists of a single penetrator attached to a payload delivery system (de-orbit motor and attitude control system) which is ejected prior to impact.

6.2 Orbiter

The Orbiter will include, for each Descent Module—accommodation, commanding and telemetry communications (health status), power, and a DM ejection mechanism.

6.2.1 Attitude and orbit control required

The AOCS (Attitude and Orbit Control System) of the LunarNet orbiter is required to perform 3-axis pointing for such tasks as orienting the spacecraft during the propulsive mission phases, antenna pointing for communications, directing solar panels towards the sun and launching penetrators towards the desired locations on the lunar surface. After the deployment of the penetrators on the surface, the orbiter will continue to operate and communicate with the surface instruments and with Earth until the end of the mission. During this time ΔV orbit maintenance will be performed to ensure adequate visibility of the surface instruments and the Earth ground station. The basic AOCS requirements are summed up below:

3-axis pointing accuracy:	1 degree
Array pointing accuracy (all phases):	5 degree
Lunar insertion pointing accuracy:	1 degree
Mission lifetime:	1.2 years

6.2.2 On-board data handling and telemetry

Prior to penetrator deployment, the orbiter will need to provide commanding and power to each onboard descent module for a limited number of occasions to enable health checks. During deployment the orbiter will be required to accept descent module health checks, and if possible descent camera images. After deployment the orbiter will need to provide regular (e.g. every 15 days) communications with the penetrators for commanding and uplink of data, and to relay this information to Earth. The orbiter will also need to accept commands from Earth and telemeter to Earth a small amount of housekeeping data to support its own orbital manoeuvres and sub-systems. To support these requirements an orbiter data handling system is envisaged which consists of

two redundant on-board computers (OBCs). On-board data handling for the 15 communication slots with the penetrators is described in Sections 6.4.2 and 6.4.3.

6.3 Penetrator delivery system

There will be four descent modules, each composed of a penetrator and an aft de-orbit and attitude control system which is ejected from the penetrator prior to penetrator impact. A descent camera will be mounted on the descent module. Table 11 provides the mass budget for the equivalent MoonLITE case (courtesy Astrium) indicating an overall mass with 15% system margin of 38.6 kg for the PDS.

A value of 50 kg is assumed here for the LunarNet Descent Module including margins. The Europa Descent Module is shown in Fig. 10, and a provisional timeline for the Descent Module descent is given in Table 12 and pictorially represented in Fig. 11. [The preliminary MoonLITE PDS design was based on a solid fuel de-orbit rocket and a liquid fuelled system for other manoeuvres. Analysis following the ESA Europa study [2] shows that a liquid

Table 11 MoonLITE descent module mass breakdown

Subsystem	Item	Unit mass [Kg]	Number	Basic mass [kg]	Margin [%]	System mass [Kg]
Propulsion	SRM	5.200	1	5.200	10	5.720
	RCS	2.744	1	2.744	10	3.018
Attitude control	MEMS IMU/gyro	0.100	1	0.100	20	0.120
	Sun sensor	0.330	1	0.330	20	0.396
Mechanisms	SUEM with orbiter	0.100	1	0.100	20	0.120
	Penetrator/PDS release	0.400	1	0.400	20	0.480
Interfaces and harness	Harnessing/umbilicals	0.650	1	0.650	20	0.780
Power	Battery	0.300	1	0.300	5	0.315
Data handling	OBC	0.400	1	0.400	20	0.480
Structure	PDS carrier structure	1.000	1	1.000	20	1.200
Communications	Antenna	0.200	1	0.200	20	0.240
PDS dry mass						12.87
System margin						15
PDS dry mass including margin						14.80
Solid propellant mass						23.68
RCS propellant mass incl.residuals						0.129
PDS TOTAL MASS						38.607
Penetrator mass						13.000
Descent module total mass						51.607

SRM solid rocket motor, *RCS* reaction control system, *IMU* inertial measurement unit, *SUEM* spin up and eject mechanism

Fig. 10 Penetrator descent module (Europa example)

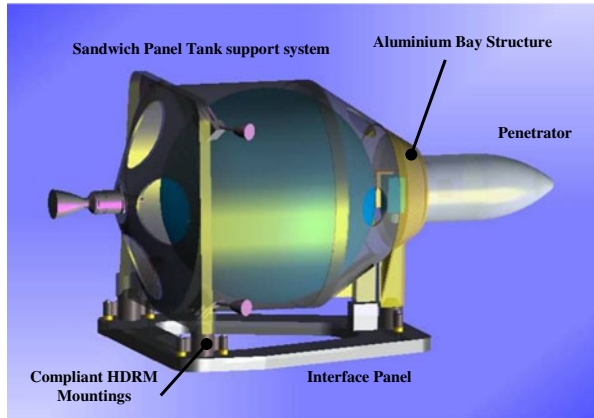

fuelled de-orbit and reaction control system would be feasible for LunarNet with some mass savings.]

A preliminary trade study was made of propulsion options for the PDS, including full mono-propulsion system; full bi-propulsion system; solid rocket + mono-propulsion system RCS (Reaction Control System); and solid rocket + cold gas RCS. The solid rocket + mono-prop RCS was selected as the baseline. The SRM (Solid Rocket Motor) is used for the deceleration and a mono-propulsion (hydrazine) system for the remaining manoeuvres. This is primarily due to the mass/volume saving over a cold gas system and the simplicity of a single propulsion system for all phases (excluding deceleration burn) opposed to solid/mono-prop combinations.

A 3-axis control approach is baselined for the attitude control based on its lower risk and relative simplicity. The sensors used must be small, inexpensive, and provide adequate attitude data. The most convenient choice of primary sensor is a 3-axis Inertia Measurement Unit (IMU) which combines a gyroscope with an accelerometer. The gyro gives rate information which then can be integrated to give attitude data. The accelerometer can be used to measure the residual horizontal component of velocity after the de-orbit burn. This knowledge can then be used to calculate the target impact attitude and any necessary rate correction for the RCS. Many COTS MEMS IMUs with good performance are now available. These can be lightweight, small, and inexpensive and the technology is improving rapidly.

Separation of the penetrator from the PDS is foreseen prior to impact, where 90 s thrust will give 5 m separation between penetrator and PDS impact locations.

6.3.1 Heritage and technical readiness levels

A Lunar-A PDS was fully developed prior to mission cancellation implying a generic TRL of the technology of TRL 6. All proposed technologies within the PDS are flight proven at component level.

Table 12 Provisional descent timeline

Event	Label	Total time (s)	Delta time (s)	Altitude (m)	Horizontal velocity (m/s)	Vertical (m/s)	Spin rate (rpm)	Description
Release + Drift	t1	0.0	10.0	24815	1700	0	TBD	Release of DM, drift
Spin-up	t2	10.0	2.5	24815	1700	0	100	Spin up to give nutational stability.
De-orbit	t3	12.5	31.6	24815	1700	0	200	Perform de-orbit manoeuvre.
Spin-down	t4	44.1	2.0	24323	120	-43.5	200	Spin down with active denutation.
Calibrate attitude	t5	46.1	2.0	24233	120	-46.9	0	Calibrate attitude with sun sensor.
Re-orientation	t6	48.1	20.0	24136	120	-50.1	0	Re-orient to target attitude.
Take photos	t7	68.1	20.0	22812	120	-82.6	0	Take photos, if required.
Spin-up	t8	88.1	3.0	20839	120	-115.0	0	Spin-up to give gyroscopic rigidity.
Separation	t9	91.1	95.6	20487	120	-119.9	100	Passive separation (spring).
Impact	t10	186.7	N/A	0	120	-275.0	100	Impact on lunar surface with total velocity <300m/s.

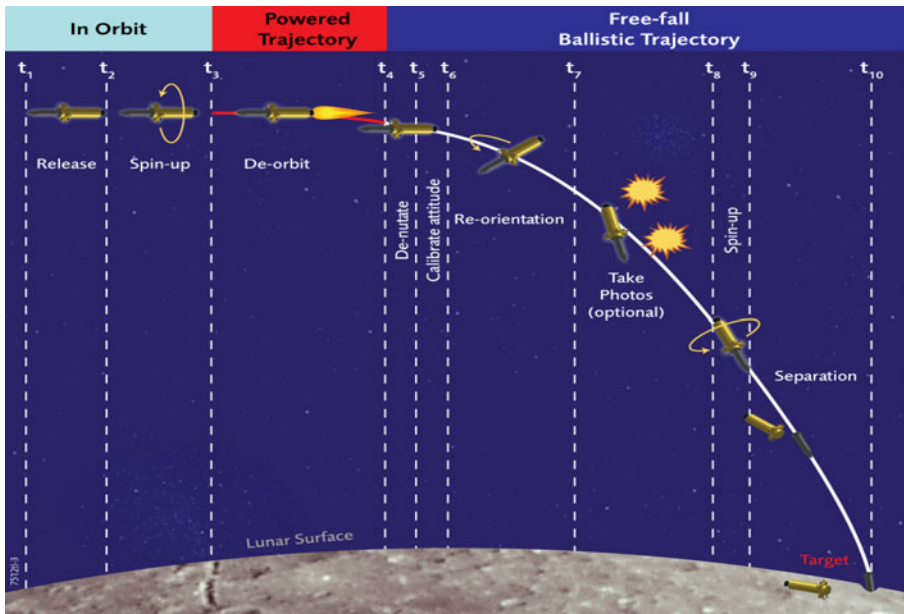

Fig. 11 Provisional descent sequence (Courtesy Astrium)

6.4 Penetrator

Some general characteristics of a penetrator and its requirements on the penetrator delivery system are provided in Table 13. Each penetrator will be ~0.5 m long and ~13 kg mass (similar to Lunar-A). They will be implemented as a simple “single-body” design (as opposed to fore-/aft-body design such as Deep Space–2). Each penetrator will consist of a supporting structure, a power system, communications system, data handling system, and payload.

A preliminary study of penetrator structure options has been carried out by QinetiQ [5]. Four alternative materials were considered, steel, aluminium alloy, titanium alloy and carbon composite. A summary of the results from this study are shown in Table 14.

These figures should be compared with an estimated payload volume requirement of:

Scientific payload elements	–1477 cm ³
Batteries	–1500 cm ³
Electronics	–1500 cm ³
Total	–4477 cm ³

This leads to an occupancy factor of 68% for an Aluminium shell (the selected baseline).

The Laplace study led to an internal design as indicated in Fig. 12, similar to that used during the Pendine trials except that the compartments inside

Table 13 Penetrator characteristics

Mass (at impact)	13 kg
Impact deceleration	Up to 20,000 gee.
Impact angle (between impact velocity vector and tangent to surface)	$\sim 90^\circ$ (not critical)
Attack angle (between penetrator long axis and impact velocity vector)	$\sim < 8^\circ$ (critical)
Penetration depth into regolith	2 to 5 m.
Ambient penetrator operating temperature:	-20°C to -50°C . (50 K to 100 K in shaded polar craters)
Mean penetrator power (subsystems and payload)	60 mW.
Mission duration	1.2 years (1 year on surface)

the shell are held away from the shell by snubbers. These enable ‘a vacuum flask concept’ to be realised which greatly reduces the otherwise dominant conductive heat transfer from the bays to the outer shell, thereby allowing a greatly increased lifetime of the penetrator in cold, highly conductive emplacements. The snubbers are designed to elastically deform during impact and recover afterward. Preliminary analysis predicts that the vacuum flask system will reduce total penetrator heat losses to ~ 0.8 W (comprising ~ 0.3 W conductive heat loss from the snubbers and ~ 0.5 W from radiation).

6.4.1 Power

Because the penetrator will be completely buried under the lunar regolith power will be entirely supplied to the penetrator systems by batteries. Initial studies for this proposal [67] indicate the use of Lithium thionyl chloride primary cells, as planned or adopted for DS-2 and Lunar-A, with an energy density of ~ 275 W h kg^{-1} . The Lunar-A team report an energy density of 430 W h kg^{-1} [40]. For these batteries, both the operating temperature and g-force survival levels have significant margins over the LunarEX requirements. The initial study indicates a battery mass of the order of ~ 2.5 kg/penetrator,

Table 14 Penetrator structure options

Penetrator shell material (for 720 mm length)	Wall thickness (mm)	Projectile internal volume (cm^3)	Projectile filling mass (kg)	Projectile all-up mass (kg)
Aluminium Alloy	6.5	6500	7.44	13.0
Steel	11.5	5700	6.5	27.4
Titanium	2.5	7300	8.46	10.8
CFRP compression moulding	7	6400	7.33	10.5

CFRP carbon fibre reinforced polymer

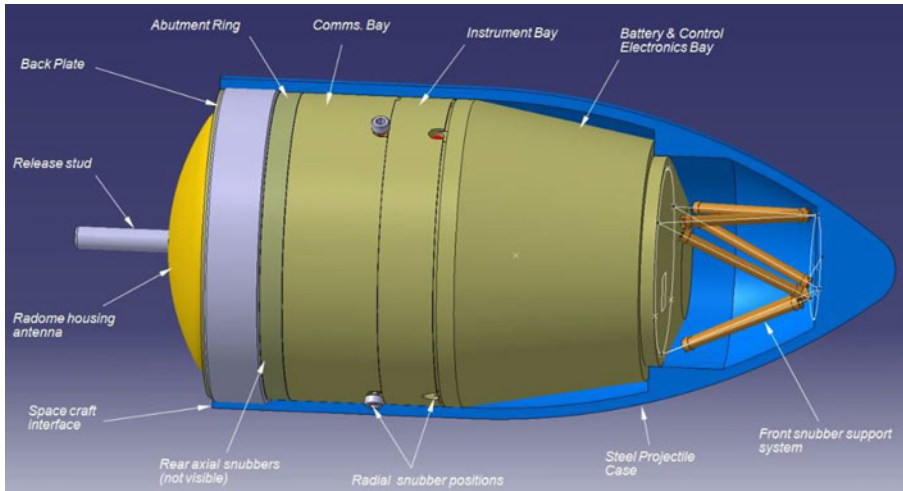

Fig. 12 Example penetrator internal design

corresponding to a capacity of ~ 550 W h (depending on the operating temperature). For non-shaded sites, operation of a penetrator comparable to Lunar-A penetrator dimensions should achieve a similar 1-year operational lifetime. For the shaded polar sites, where there are much lower temperatures, extended operations will require careful consideration of insulation and could greatly benefit from use of RHUs (Radioisotope Heating Units).

6.4.2 Onboard data handling and telemetry

Because of the expected infrequent communication contacts with the orbiter, (>2 /month depending upon penetrator latitude) each penetrator will need to operate autonomously, collecting, compressing, and storing data until each uplink opportunity. A small commanding capability is necessary to allow optimization of seismic data selection and data volume reduction. Because of the low radiation environment an FPGA (Field Programmable Gate Array), small micro-controller or micro-processor solution with relatively high density memory, will be strong candidates for this mission. The nature of the scientific payload will naturally allow for a high degree of sequential operation with initial uplink of descent camera images and accelerometer data collected during impact. This will be followed by geochemical and temperature data. Heat flow measurements will not be possible until after thermal stabilization, possibly after a whole lunar cycle or more has passed. The seismometer will be the only instrument required to operate more or less continuously throughout the whole mission, that has substantial data generating ability. This will allow, as resources permit, a significant processing and memory storage saving via natural prioritisation. In addition it will be planned to select only the most significant seismic data for transmission.

Assuming a 90 s uplink window within a single 12 min contact period per penetrator every 15 days, an uplink rate to the orbiter of 5 kbits/s will be sufficient to return an estimated total data volume of 12 Mbits (with a 40% margin) within the 1 year lifetime. The data return is dominated by the seismometer for which approximately half of the telemetry is allocated. The recent ESA Europa study [2], indicates that this is feasible as a minimum capability, and with potential for achieving a factor 4 or more higher depending the penetration depths and signal attenuation levels which are expected to be low for both the Moon and Europa. For four penetrators the orbiter is required to relay an average of 120 kbits/day from the orbiter to the Earth.

6.4.3 Communications

One contact/penetrator every 15 days corresponds to a total of ~ 2 W h for the necessary 90 s transmission contacts (in a general 12 min window). A similar amount will be required for the receiver leading to around 4 W h which is $< 1\%$ of the total power budget, with $\sim 99\%$ of the power left for payload and data handling.

The baseline communications design is a body antenna mounted at the aft (trailing) end of the penetrator. The antenna would be conformed to the surface of the penetrator, to ensure a smooth, projection free surface. As the body diameter is quite small for a UHF (Ultra High Frequency) antenna, a helical or similar antenna may be needed; alternatively dielectric loading could be employed at the expense of mass. The dielectric properties of the regolith need to be taken into account in designing the antenna in order to optimise performance when buried. Testing would also need to replicate these conditions. The ruggedised UHF transceiver built by QinetiQ for the Beagle 2 mission to Mars is proposed as a starting point. Its mass is approximately 600 g, and its design is based on the highly successful MELACOM transponder, currently in operation in Mars Orbit. MELACOM would be a logical unit to deploy on the Orbiter. The design could be updated and miniaturised for the LunarNet mission, with an emphasis on the engineering to survive the severe impact environment. Study of the link budget shows that a 0.5 W omni-directional UHF transmitter on the penetrator can transmit 15 days of data to the orbiter in ~ 90 s with a more than adequate ~ 30 dB margin. The composition of the lunar regolith will have a significant impact on the achieved margin of the link for which a minimum margin of 20 dB has been assumed to account for possible regolith attenuation on the link.

6.4.4 Heritage and technical readiness levels

The heritage of penetrator elements is discussed below and their estimated TRLs are provided in Table 15.

1. Shell: for a shell with no apertures there is extensive Earth based defence sector heritage at impact velocities in excess of 300 m s^{-1} , and space

Table 15 Penetrator item TRLs

Penetrator item	TRL	Comments
Shell	4-5	No apertures: Design modelled, and similar designs have survived impact with gee forces we expect.
Vacuum flask bay system	1-2	Apertures: Concept developed.
	2-3	Concept designed and analysed. A fallback would be a penetrator design as proposed for LunarEX employing additional batteries, or having a shorter lifetime, especially for colder emplacements.
Communications	4-5	Modification of existing communications systems with extensive space heritage, and impact hardened.
Power (batteries)	3	Commercial provided.
Management system(DPU, PCU)	4-5	Modification of existing technology with extensive space heritage, and Pendine impact trial impact survival.
Sample acquisition and handling	3	Drill assembly.
	1-2	Outer shell penetration

DPU data processing unit, *PCU* power conditioning unit

implementation heritage with DS2, Lunar-A, and Mars-96. For a shell requiring apertures, heritage exists via the DS2 implementation of a drill which drilled through the side of the penetrator wall. A new element of shell design is use of titanium alloy material.

2. Vacuum flask bay system: No heritage.
3. Communications: based around the Beagle-2 and MELACOM UHF design.
4. Power (Batteries): Commercial batteries are baselined with Li-SOCl₂ which has extensive space heritage, but not impact heritage.
5. Penetrator Management System: This will be an adaption of data processing and control units that MSSL (Mullard Space Science Laboratory) has built for many space systems, and of the particular development for the successful Pendine impact trial design.

6.5 Mission operations concept (ground segment)

For the relatively brief mission phases encompassing operations from launch to the Moon; the four penetrator deployment events and commissioning will require significant human operator monitoring, whereas the majority of the 1 year mission could be operated with minimal human intervention. Ground reception and commanding facilities would only be required for the remainder of the time to cover short intervals (e.g. 30 min periods for each penetrator's once in 15-day data uploads and associated commanding from the orbiter). Operations with the orbiter outside these periods could be performed autonomously. Suitable ground station networks could comprise a mixture of UK

and other commercial ground stations (such as used by SSTL for the Giove-A mission) and ESA facilities.

6.6 Estimated overall resources

1. Mass: Preliminary LunarNet mass estimates are provided in Table 16.

Since the available mass that can be delivered into lunar orbit with a Soyuz-Fregat is 1250 kg, a margin of 328 kg is available.

2. Power: Power for the landed penetrators will be supplied by primary batteries providing 550 W h (See 6.4.1). Power for the orbiter is modest as there is no orbital payload. It is envisaged that the orbiter power will be provided by solar cells supplemented by batteries. The provision of suitable solar power and battery capacity will need to take into account large (e.g. 40%) solar eclipses in a low lunar polar orbit. Because of the difficulty of locating solar cells on the walls of the orbiter due to the accommodation requirements of the descent modules, a deployable solar array system is envisaged. Comparing power requirements with Mars Express leads to a preliminary estimate of ~ 450 W for the orbiter.

6.7 Specific environmental constraints

6.7.1 EMC/EMI (*Electro-Magnetic Cleanliness/Electro-Magnetic Interference*)

No unusual requirements are foreseen in this area. Detailed requirements will be developed during phase A.

Table 16 LunarNet mission mass estimate for nominal 4 penetrator payload (extrapolated from Gao et al. [18])

Item	Mass (kg)
Structure	131.0
Communications	8.4
Power	28.7
Solar panels	15.3
AOCS	44.1
Propulsion	66.1
OBDH	6.5
Environmental	16.6
Harness	30.0
Payload (4 penetrator descent modules)	206.4
System margin (platform)	34.7
Total (dry)	587.8
Propellant (transfer, LOI, orbit maintenance)	323.2
AOCS propellant	11
Propellant (Total)	334.2
Total (Launch)	922

6.7.2 Radiation

The spacecraft will most likely be injected into an initial GTO orbit, using its own propulsion to transfer into the desired lunar transfer orbit. Even so, the spacecraft will spend very little time traversing the Van Allen Belts. Therefore, the total dose induced will be small (<2 krad(Si)) for transfer and a mission lifetime of 1 year in lunar orbit, while remaining less than 5 krad (Si) for 5 years in orbit.

The probability of single event latch-up damaging the mission must also be quantified. In the lunar environment the heavy ion spectral density will be similar to the MEO environment (GIOVE-A orbit). Therefore, the equipment with GIOVE-A heritage are suitable for this mission without the need for increased radiation protection (they have already experienced an $m = 7$ solar flare). In addition, this spacecraft is protected with redundant systems and current monitoring at suitable locations. Over-current conditions lead to the automatic shutdown of the system. This approach has proven to offer robustness at a system level.

The penetrators themselves will be buried below >2 m of regolith and so will be relatively well shielded.

6.7.3 Thermal

The spacecraft thermal environment has been assessed with the spacecraft in its operational orbit. With the spacecraft in yaw steering mode heat can be dissipated via conventional passive radiative surfaces. Cold case conditions (i.e. eclipses) will require the use of electrical heaters.

The penetrator thermal environment depends upon their location but can be as cold as 40 K in a permanently shaded crater [47]. For this reason a vacuum flask concept has been proposed by MSSL and reported in the Laplace study [2]. RHUs for heating will be evaluated as part of a Phase A study.

6.7.4 Cleanliness

Some limitations may be imposed upon lunar impact sites related to planetary protection. However, given the wide choice of sites available and the history of impact of man-made objects onto the lunar surface (more than 70) this is not likely to be an issue.

6.8 Proposed procurement approach

- Spacecraft: Prime contractor
- PDS: Sub-contractor
- Penetrator: National agencies
- Ground operations: Prime contractor or Third Party

7 Science operations and archiving

It is assumed that the agency will be responsible for spacecraft operations support, including telemetry, immediate health and safety monitoring, and any commanding that may be included. The scientific consortium will be responsible for detailed specification of agency operation requirements, more detailed health and safety analysis, calibration, scientific data analysis, and command generation.

7.1 Science operations architecture and share of responsibilities

Science operations for this mission are envisaged as follows:

1. Orbiting support spacecraft—Intense operational support will be required for the launch, early post launch phase, orbital manoeuvre changes, and then at a low level for regular spacecraft health and safety (housekeeping) monitoring throughout the nominal 1 year mission.
2. Penetrators—It is envisaged that there will be intense operational support for pre-deployment health and safety checks, follow by orbital deployment, and impact. Deployment of penetrators will occur at approximately 2 week intervals. Contact with each penetrator is expected every 15 days (more frequently for polar penetrators). After the initial 1–2 contacts, only the seismometer and heat flow experiments will be operating, so that operational support will be reduced.

In summary, operational support during the first 3 months will be relatively intense with a co-located science team assessing data and optimising the payload operations. For the latter part of the mission (following 9–12 months) operations will be relatively routine.

7.2 Archive approach

All scientific data should be archived. It is noted that the total penetrator data volume is expected to be relatively small at ~ 30 kbytes/day, generating $11 \text{ Mbytes year}^{-1} \times 4 \text{ penetrator mission} = 44 \text{ Mbytes}$ for a complete 1 year mission.

7.3 Proprietary data policy

Much of the mission science data analysis will depend upon the acquisition of a full set of data that is well understood and calibrated. For this reason the scientific data shall only be made public 6 months after the end of the mission. However, data of public interest from the descent cameras will be made publicly available immediately.

8 Technology development requirements

8.1 Payload technology challenges and technology development strategy

All payload instruments are based upon proven space applications or are currently under development for other space missions. However, since relatively few high velocity impact missions have been flown, the majority of the payload must be ruggedized. The Pendine trials indicated that this was an entirely feasible approach given the level of experience regarding such impacts available to the team. The general approach to ruggedization of payload instruments involves the following [6]:

- Determination of lunar regolith properties from available source material and geological considerations
- Impact modelling to determine likely shock loading and shock-induced stress
- Small scale modelling and impact trials (e.g. at the Cavendish Laboratories in Cambridge, UK)
- Full scale design qualification at Pendine

Within the payload instruments the following are the most critical developments:

- Impact hardening of the micro-seismometer through the use of a volatile packing material
- Drill (with option to use passive sample acquisition or aperture if necessary)
- Heat flow feasibility through modelling the thermal disturbance of the regolith.

To permit flexible trials and facilitate AIT/AIV (Assembly Integration Testing and Verification), the strategy of using an inner-bay design (see [56]) will be continued. This approach allows clear interface definition and permits sub-system testing in isolation.

Within the penetrator the following areas require short-term development or study:

- Snubbed shell approach—thermal and impact modelling and trials
- Penetrator Aperture—impact modelling and trials
- Power system (battery) performance at low temperatures
- Penetrator packing material behaviour at low temperatures
- Communication system demonstration and modelling of the effects of the overlying regolith

8.2 Mission and spacecraft technology challenges

The penetrator delivery system is a spacecraft in its own right, albeit with a lifetime of only a few minutes. Following the EADS Astrium study of MoonLITE the following technological challenges were identified:

Guidance, Navigation & Control

- Location/Attitude detection and algorithmic handling
- Control to reach the impact zone
- Rotational dynamics of the Descent Module

De-orbit stability and rocket motor accuracy

- To ensure a predictable de-orbit burn within the requirements

Mass, Cost, and Risk

- Technology selection /TRL level de-risking
- Resource sharing between the penetrator and orbiter

Validation Testability

- Ensuring that the design can be validated before flight

On-orbit Testing and Reconfiguration

- Enabling adequate testing and reconfiguration prior to release at the Moon
- Analysis of descent communications

9 Preliminary programmatic/costs

9.1 Overall proposed mission management structure

LunarNet is proposed as an ESA mission with international collaboration only occurring at the level of the penetrator and payload. (Possible involvement in EJSM mission could produce cost savings via bilateral arrangements and joint development of the penetrator system)

9.1.1 Basic integration and verification approach and model philosophy

The verification and validation approach for penetrators is:

- a) Component level verification and validation through modelling, and small scale impact testing, and performance testing.
- b) Integrated level verification through large scale (Pendine) impact trials, including, during trial and post impact performance testing.

Model philosophy and schedule (relaxed from the Europa TDA (Technical Development Activities) study) is provided in Table 17 for a late 2020 launch. A later launch will provide more contingency.

9.2 Mission schedule drivers/risks

Major mission schedule drivers/risks are:

- Timely provision of funds to complete TRL5 Technology developments by end 2014. (In particular to extend the demonstration of impact survival to all penetrator elements, beyond the MoonLITE subset involved in the successful initial Pendine full scale impact trial. Expectation of imminent follow on ESA funding to demonstrate impact survival of penetrator elements)
- Timely agreement and definition of bi-lateral arrangements on penetrator technology, to allow partition of elements to contributing nations. Risk of insufficient national funding support for penetrator.

9.3 Payload/instrument cost

It is proposed that the penetrators should be provided by ESA nations with non-ESA collaboration, while the Penetrator Delivery System should be funded by ESA.

9.3.1 Assumed share of payload costs to ESA

It is assumed that all payload costs will be provided by national funding.

9.3.2 Estimated non-ESA payload costs

Estimated non-ESA payload costs are 75 MEuros, which assumes selection of the most capable but expensive mass spectrometer of ~15 MEuros. (Using payload cost estimates provided to the recent ESA TDA studies, a reasonable instrument suite composed of 5 instruments is estimated to cost ~20 MEuros.

Table 17 LunarNet model philosophy and schedule

Model	Schedule	Comments
BB Breadboard model	2014 1 year	Phase A/B1.
STM Structural & Thermal model	2014–2015 1 year	Depending on when required.
EM Engineering model	2015–2016 2 year	Impact survival - flight quality parts.
QM Qualification model	2017 1 year	Functional and environmental performance model.
FM Flight model	2018 1 year	Fabrication and unit testing.
	2019 1 year	Penetrator AIT followed by PDS AIT.
	Start 2020 –	PDM delivery to Orbiter
FS Flight spare	2018–2019 2 year	Possible refurbishment of QM.

Table 18 Mars express—LunarNet comparison

Aspect	Mars express	LunarNet
Launch mass (kg)	1223	922
Launcher	Soyuz Fregat	Soyuz Fregat
Mission duration	> 4 years	1.2 year
Mass of surface element	71 kg (33 kg Beagle-2)	206 kg (descent modules) (4 × 13 kg penetrators)
Mass of orbiting payload	116 kg	0 kg
Mass of fuel	426 kg	334 kg
Launch dry mass (i.e. launch mass - fuel)	797 kg	588 kg
ESA Costs (M€)	204	204 ^a
National costs (M€)	~ 100	~ 75

^aReductions can be envisaged from reduced operations costs from 1 year mission only. Additional cost of de-orbit and attitude control units is offset by the savings achieved from the absence of an orbiter scientific payload

Assuming a 25% cost saving on replication of build costs of instruments for 4 penetrators, plus 1 instrument spare, leads to a total cost of 75 MEuros.)

9.4 Overall mission cost analysis

Table 18 shows a simple comparison between Mars Express and LunarNet. MEX and LunarNet appear similar in that both involve a planetary orbiter element and a surface element.

Assuming operation costs for 1 year at 50 MEuros, the total cost to ESA is 254 MEuros.

10 Communication and outreach

The Lisbon European Council Meeting in March 2000, in the celebrated “Lisbon Declaration” recognized the important role of education as an integral part of economic and social policies for strengthening Europe’s competitive position worldwide. The meeting set the strategic objective for the European Union to become the world’s most dynamic knowledge-based economy.

However in summing up the outcome of the recent Space Education Forum held in June, 2007 at the international Space Science Institute in Bern, the Executive Director Professor Roger M. Bonnet remarked “that the aims of the Lisbon Declaration are pursued energetically in the USA but apparently no longer in Europe”

Europe is critically short of young scientists and engineers. Of all the domains that have the potential to inspire, Space remains at the forefront. Within the Space domain, planetary science and exploration is probably the most engaging to the public.

LunarNet has the potential to be a very high profile mission. It will be novel and exciting and will take place at a time when lunar exploration has

re-emerged in the public eye. A general sense of ‘Humankind returning to the Moon’ is growing and we can expect to see a dramatic increase in interest. This will improve public awareness of the issues that the mission seeks to address (origin of the Earth, implications of water ice on potential for manned planetary exploration and space exploration relevant to studies of the origin of life).

The relatively short duration of the first phase will include a number of significant events (launch, orbit insertion, four surface deployments and four ‘first light’s plus potential water discovery and, later lunar seismic discoveries) which should maintain public interest and media coverage. While comparisons with Apollo will be made, it will also be noted that at least two penetrators will impact in locations which were not accessible to Apollo (Far-side and permanently shaded craters): thus it will be easy to communicate that significant advances being made by LunarNet.

Within this context it is proposed to plan an outreach programme linked to key mission milestones. Live coverage of impacts and first transmission is a strong possibility since through ESA ownership, confidence will be very high. Descent images transmitted in near real time will be reminiscent of the first Ranger photographs.

Moreover, the high technology, and apparently highly challenging nature of the penetrator concept offers a showcase for European technology.

Acknowledgements Elements of this study were supported by the UK Science and Technology Facilities Council, and other international funding agencies including contribution 1632 from the Lunar and Planetary Institute.

References

1. Araki, H., Sasaki, S., Ishihara, Y., Noda, H., Hanada, H., Matsumoto, K., Kikuchi, F., Goossens, S., Namiki, N., Iwata, T.: The first global topography and gravimetry of the Moon by Kaguya. EPSC Abstracts, 2010–427 (2010)
2. Astrium: 2010, Contract Report to ESA: Design Update for Europa Issue-1, (JGOP-ASU-TN-006–1 PDM), 13 August 2010
3. Binder, A.B., Oberst, J.: High stress shallow Moonquakes: evidence for an initially totally molten Moon. *Earth Planet. Sci. Lett.* **74**, 149–154 (1985)
4. Bulow, R.C., Johnson, C.L., Bills, B.G., Shearer, P.M.: Temporal and spatial properties of some deep Moonquake clusters. *J. Geophys. Res.* **112**, E09003 (2007). doi:[10.1029/2006JE002848](https://doi.org/10.1029/2006JE002848)
5. Church, P.: QinetiQ, LunarEX study report (2007)
6. Church, P., Huntington-Thresher, W., Bruce, A., Penny, N., Smith, A., Gowen, R.: Demonstration of Survivable Space Penetrator, Proc APS Conference, Nashville, USA (2009)
7. Chyba, C.F., Sagan, C.: Endogenous production, exogenous delivery and impact-shock synthesis of organic molecules: an inventory for the origins of life. *Nature* **355**, 125–132 (1992)
8. Colaprete, A., Schultz, P., Heldmann, J., Wooden, D., Shirley, M., Ennico, K., Hermalyn, B., Marshall, W., Ricco, A., Elphic, R.C., Goldstein, D., Summy, D., Bart, G.D., Asphaug, E., Korycansky D., Landis D., Sollitt L.: Detection of water in the LCROSS ejecta plume. *Science* **330**, 463–468 (2010)
9. Crawford, I.A.: The scientific case for renewed human activities on the Moon. *Space Policy* **20**, 91–97 (2004)

10. Crawford, I.A., The astrobiological case for renewed human and robotic exploration of the Moon. *Int. J. Astrobiol.* **5**, 191–197 (2006)
11. Crider, D.H., Vondrak, R.R.: Hydrogen migration to the lunar poles by solar wind bombardment of the Moon. *Adv. Space Res.* **30**, 1869–1874 (2002)
12. ESA, D.: Southwood, Call for a Medium-size mission opportunity for a launch in 2022, D/SRE/DJS/FF/ve/26771, Paris, 29 July 2010
13. Ewing, M., Latham, G., Press, F., Sutton, G., Dorman, J., Nakamura, Y., Meissner, R., Duennebier, F., Kovach, R.: Seismology of the Moon and implications on internal structure, origin and evolution. In: De Jager, (ed.) *Highlights of astronomy*, pp. 155–172, D. Reidel, Dordrecht (1971)
14. Feldman, W.C., Maurice, S., Binder, A.B., Barraclough, B.L., Elphic, R.C., Lawrence, D.J.: Fluxes of fast and epithermal neutrons from Lunar Prospector: evidence for water ice at the lunar poles. *Science* **281**, 1496–1500 (1998)
15. Frohlich, C., Nakamura, Y.: Possible extra-Solar-System cause for certain lunar seismic events icarus. **185**, 21–28 (2006)
16. Fulchignoni, M., Ferri, F., Angrilli, F., Bar-Nun, A., Barucci, M.A., Bianchini, G., Boruck, W., Coradini, M., Coustenis, A., Falkner, P., Flamini, E., Grard, R., Hamelin, M., Harri, A.M., Leppelmeier, G.W., Lopez-Moreno, J.J., McDonnell, J.A.M., McKay, C.P., Neubauer, F.H., Pedersen, A., Picardi, G., Pirronello, V., Rodrigo, R., Schwingenschuh, K., Seiff, A., Svedhem, H., Vanzani, V., Zarnecki, J.: The characterisation of Titan's atmospheric physical properties by the Huygens atmospheric structure instrument (Hasi). *Space Sci. Rev.* **104**(1), 395–431 (2002)
17. GES (2007) The global exploration strategy: framework for coordination. Available online at: http://esamultimedia.esa.int/docs/GES_Framework_final.pdf. Accessed 25 March 2011
18. Gao, Y., Phipps, A., Taylor, M., Crawford, I.A., Ball, A.J., Wilson, L., Parker, D., Sweeting, M., da Silva Curiel, A., Davies, P., Baker, A., Pike, W.T., Smith, A., Gowen, R.A.: Lunar science with affordable small spacecraft technologies: MoonLITE and Moonraker. *Planet. Space Sci.* **56**, 368–377 (2008)
19. Gehler, M., Wielders, A.: Payload definition document for a jupiter icy moon penetrator, SCI-PA/2009.076 (2010)
20. Glotch, T.D., Lucey, P.G., Bandfield, J.L., Greenhagen, B.T., Thomas, I.R., Elphic, R.C., Bowles, N., Wyatt, M.B., Allen, C.C., Hanna, K.D., Paige, D.A.: Highly silicic compositions on the Moon. *Science* **329**, 1510–1513 (2010)
21. Goins, N.R., Dainty, A.M., Toksöz, M.N.: Lunar seismology – the internal structure of the Moon. *J. Geophys. Res.* **86**, 5061–5074 (1981)
22. Gowen, R.A. et al.: Penetrators for in situ sub-surface investigations of Europa. *Adv. Space Res.* (2010). doi:[10.1016/j.asr.2010.06.026](https://doi.org/10.1016/j.asr.2010.06.026)
23. Greenhagen, B.T., et al.: Global silicate mineralogy of the Moon from the Diviner lunar radiometer. *Science*, **329**, 1507–1509 (2010)
24. Griffiths, A.D., Coates, A.J., Jaumann, R., Michaelis, H., Paar, G., Barnes, D., Josset, J.-L., and the PanCam team: Context for the ESA ExoMars Rover: the Panoramic Camera (PanCam) Instrument. *Int. J. Astrobiol.* **5**, 269–275. doi:[10.1017/S1473550406003387](https://doi.org/10.1017/S1473550406003387) (2006)
25. Hagermann, A.: Planetary heat flow measurements. *Phil. Trans. R. Soc. A* **363**, 2777–2791 (2005)
26. Hagermann, A., Tanaka, S: Ejecta deposit thickness, heat-flow, and a critical ambiguity on the Moon. *Geophys. Res. Lett.* **33**, L19203 (2006)
27. Hopf, T., Kumar, S., Karl, W.J., Pike, W.T.: Shock protection of penetrator-based instrumentation via a sublimation approach. *Adv. Space Res.* **45**, 460–467 (2010)
28. ILN Final Report: Science Definition Team for the ILN Anchor Nodes, NASA, pp. 45. (http://ntrs.nasa.gov/archive/nasa/casi.ntrs.nasa.gov/20090014121_2009013378.pdf) (2009)
29. Jolliff, B.L., Gillis, J.J., Haskin, L.A., Korotev, R.L., Wieczorek, M.A.: Major lunar crustal terranes: surface expressions and crust-mantle origins. *J. Geophys. Res.* **105**(E2), 4197–4216 (2000)
30. Jolliff, B.A., et al. (eds). *New views of the Moon*. *Rev. Min. Geochem.*, **60**, 1–721, (2006)
31. Khan, A. An inquiry into the lunar interior – a non-linear inversion of the Apollo seismic data. *J. Geophys. Res.* **107**, 1–23 (2002)
32. Langseth, M.G., Keihm, S., Peters, K.: Revised lunar heat-flow values. *Lunar Planet. Sci. Conf.* **7**, 3143–3171 (1976)

33. Lognonné, P. Planetary seismology. *Ann. Rev. Earth. Planet. Sci.* **33**, 571–604 (2005)
34. Lognonné, P., et al.: A new seismic model of the Moon. *Earth Planet. Sci. Lett.* **211**, 27–44 (2003)
35. Lognonné, P., Johnson, C.L.: Planetary Seismology. *Treatise Geophys.* **10**, 69–123 (2007)
36. Lucey, P.G.: Potential for prebiotic chemistry at the poles of the Moon. *Proc. SPIE* 4137, (2000)
37. May, R.D., Webster, C.R.: Data-processing and calibration for uneable diode-laser harmonic absorption spectrometer. *J. Quant. Spectrosc. Radiant. Transfer* **49**, 335–347 (1993)
38. Mizutani, H., Fujimura, A., Hayakawa, M., et al.: In: Kömle, N.I., Kargl, G., Ball, A.J., Lorenz, R.D. (eds.) *Penetrometry in the solar system*, pp. 125–136. Austrian Academy of Sciences Press, Vienna (2001)
39. Mizutani, H., Fujimura, A., Tanaka, S., Shiraishi, H., Nakajima, T.: Lunar-A mission: goals and status. *Adv. Space Res.* **31**(11), 2315–2321 (2003)
40. Mizutani, H., Fujimura, A., Tanaka, S., Shiraishi, H., Nakajima, T.: Lunar-A mission: outline and current status. *J. Earth Sys. Sci.* **114**(6), 763–768 (2005)
41. Mosher, T.J., Lucay, P.: Polar night: a lunar volatile expedition. In: *Proc. 5th IAA International Conference on Low Cost Planetary Missions* (2003)
42. Nakamura, Y., Latham, G.V., Dorman, H.J., Ibrahim, A.-B.K., Koyama, J., Horvath, P.: Shallow Moonquakes: depth, distribution and implications as to the present state of the lunar interior. *Proc. Lunar Planet. Conf.* **10**, 2299–2309 (1979)
43. Nakamura, Y.: Seismic velocity structure of the lunar mantle. *J. Geophys. Res.* **88**(1983), 677–686 (1983)
44. Neal, C.R.: The importance of establishing a global lunar seismic network. Paper presented at the 2005 Space Resources Roundtable, Abstract #2065, (2005)
45. National Research Council (NRC), *The Scientific Context for Exploration of the Moon*, Final Report, Natl. Acad. Press, pp. 113. Washington, D. C. (2007)
46. Overmaat, T: *Optimisation of a Lateral Capacitive Array Transducer* M.Sc. Thesis, Imperial College London (2005)
47. Paige, D.A., et al.: Diviner Lunar radiometer observations of cold traps in the Moon's South Polar Region. *Science* **330**, 479–482 (2010)
48. Peterson, J.: Observations and modeling of seismic background noise. *U. S. Geol. Surv., Open File Rep.* 93–322 (1993)
49. Pierazzo, E., Chyba, C.F.: Amino acid survival in large cometary impacts. *Meteorit. Planet. Sci.* **34**, 909–918 (1999)
50. Pieters, C.M., et al.: Character and spatial distribution of OH/H₂O on the surface of the Moon seen by M³ on Chandrayaan-1. *Science* **326**, 568–572 (2009)
51. Pike, W.T., Standley, I.M.: Determination of the dynamics of micromachined lateral suspensions in the scanning electron microscope. *J. Micromech. Microeng.* **15**, S82–S88 (2005)
52. Pike, W.T., Karl, W.J., Kumar, S., Vijendran, S., Semple, T.: Analysis of sidewall quality in through-wafer deep reactive-ion etching. *Microelectron. Engng.* **73–74**, 340 (2004)
53. Pike, W.T., et al.: *Micromachined Accelerometer* U.S. Patent 7,036,374 (2006)
54. Seidensticker, K.J., et al.: Sesame - an experiment of the Rosetta Lander Philae: objectives and general design. *Space Sci. Rev.* **128**(1), 301–337 (2007)
55. Smith, A., et al.: LunarEX – a proposal to cosmic vision. *Exp. Astron.* **23**, 711–740 (2009)
56. Smith, A., et al.: Application of penetrators within the solar system, technology challenges and status. *Ad. Geosci.* **19**, 307–320 (2010)
57. Simoes, F., et al.: A Mutual Impedance Probe for Measuring the Dielectric Properties of the Atmosphere and Surface of Planetary Environments. 4th Int. Planet. Probe Workshop, JPL (2006).
58. Smrekar, S., Smrekar, S., Catling, D., Lorenz, R., Magalhaes, J., Moersch, J., Morgan, P., Murphy, J., Murray, B., Presley-Holloway, M., Yen, A., Zent, A., Blaney, D.: Deep Space 2: the Mars microprobe mission. *J. Geophys. Res.* **104**(E11), 27013–27030 (1999)
59. Spudis, P.D.: *The Once and Future Moon*, Smith. Inst. Press (1996)
60. Surkov, Y.A., Kremnev, R.S.: Mars-96 mission: mars exploration with the use of penetrators. *Planet. Space Sci.* **46**(11–12), 1689–1696 (1998)
61. Tanaka, S., Yoshida, Hayakawa, M., Horai, K., Fujimura, A., Mizutani, H.: Development of the heat flow measurement system by the Lunar-A penetrators. *Adv. Space Res.* **23**, 1825–1828 (1999)

62. Tanaka, S., Yoshida, S., Hayakawa, M., Fujimura, A., Mizutani, H.: Thermal Model of the Lunar-A Penetrator and its effect on the accuracy for Lunar heat flow experiment, ESA SP-462 (2000)
63. Talboys, D.L., Potts, P.J., Fraser, G. W., Butcher, G., Wegrzynek, D.: “The comparative analytical performance of the Beagle 2 X-ray Spectrometer for in situ geochemical analysis on Mars.” *X-Ray Spectrom.* **38**(5), 417–428 (2009)
64. Trotignon, J.G., et al.: RPC-MIP: the mutual impedance probe of the Rosetta plasma consortium. *Space Sci. Rev.* **128**(1), 713–728 (2007)
65. Vaniman, D., Reedy, R., Heiken, G., Olhoeft, G., Mendell, W.: The lunar environment. In: *The Lunar Sourcebook*, CUP, pp. 27–60. (1991)
66. Weber, R.C., Lin, P.-Y., Garnero, E.J., Williams, Q., Lognonné, P.: Seismic detection of the lunar core. *Science* **331**, 309–312 (2011)
67. Wells, N.: LunarEX Penetrator Power and Communications Study Technical Note. Issue 1, QinetiQ, 01-June-2007
68. Wieczorek, M.A., Phillips, R.J.: The Procellarum KREEP Terrane: implications for mare volcanism and lunar evolution. *J. Geophys. Res.* **105**(E8), 20417–20430 (2000)
69. Wieczorek, M.A., Jolliff, B.L., Khan, A., Pritchard, M.E., Weiss, B.P., Williams, J.D., Hood, L.L., Righter, K., Neal, C.R., Shearer, C.K., McCallum, I.S., Tompkins, S., Hawke, B.R., Peterson, C., Gillis, J.J., Bussey, B.: New views of the Moon. *Rev. Min. Geochem.* **60**, 221–364 (2006)
70. Wielandt, E., Streckeisen, G.: The leaf spring seismometer: design and performance. *Bull. Seism. Soc. Am.* **49**, 294–303 (1982)
71. Wilson, L., Head, J.W.: Lunar Gruithuisen and Mairan Domes: rheology and mode of emplacement. *J. Geophys. Res. - Planets* **108**(E2), 5012 (2003). doi:[10.1029/2002JE001909](https://doi.org/10.1029/2002JE001909)
72. Wright, I.P., Barber, S.J., Morgan, G.H., Morse, A.D., Sheridan, S., Andrews, D.J., Maynard, J.M., Yau, D., Evans, S.T., Leese, M.R., Zarnecki, J.C., Kent, B.J., Waltham, N.R., Whalley, M.S., Heys, S.C., Drummond, D.L., Edeson, R.L., Sawyer, E.C., Turner, R.F., Pillinger, C.T.: Ptolemy – an instrument to measure stable isotopic ratios of key volatiles on a cometary nucleus. *Space Sci. Rev.* **128**(1–4), 363–381 (2007)